

ROTARY CAM SWITCHES 4G SERIES

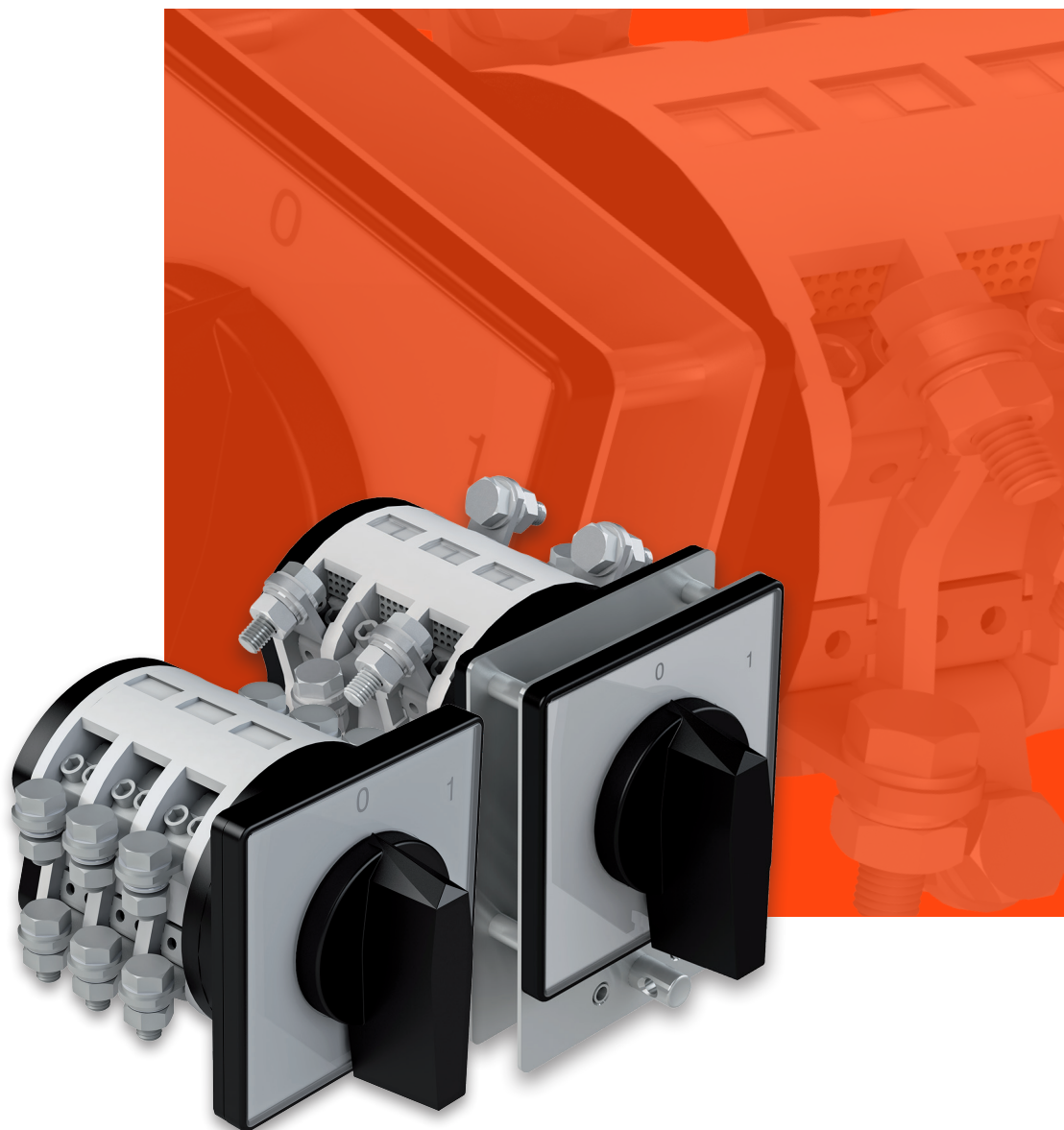

 **Lovato**
electric

ENERGY AND AUTOMATION

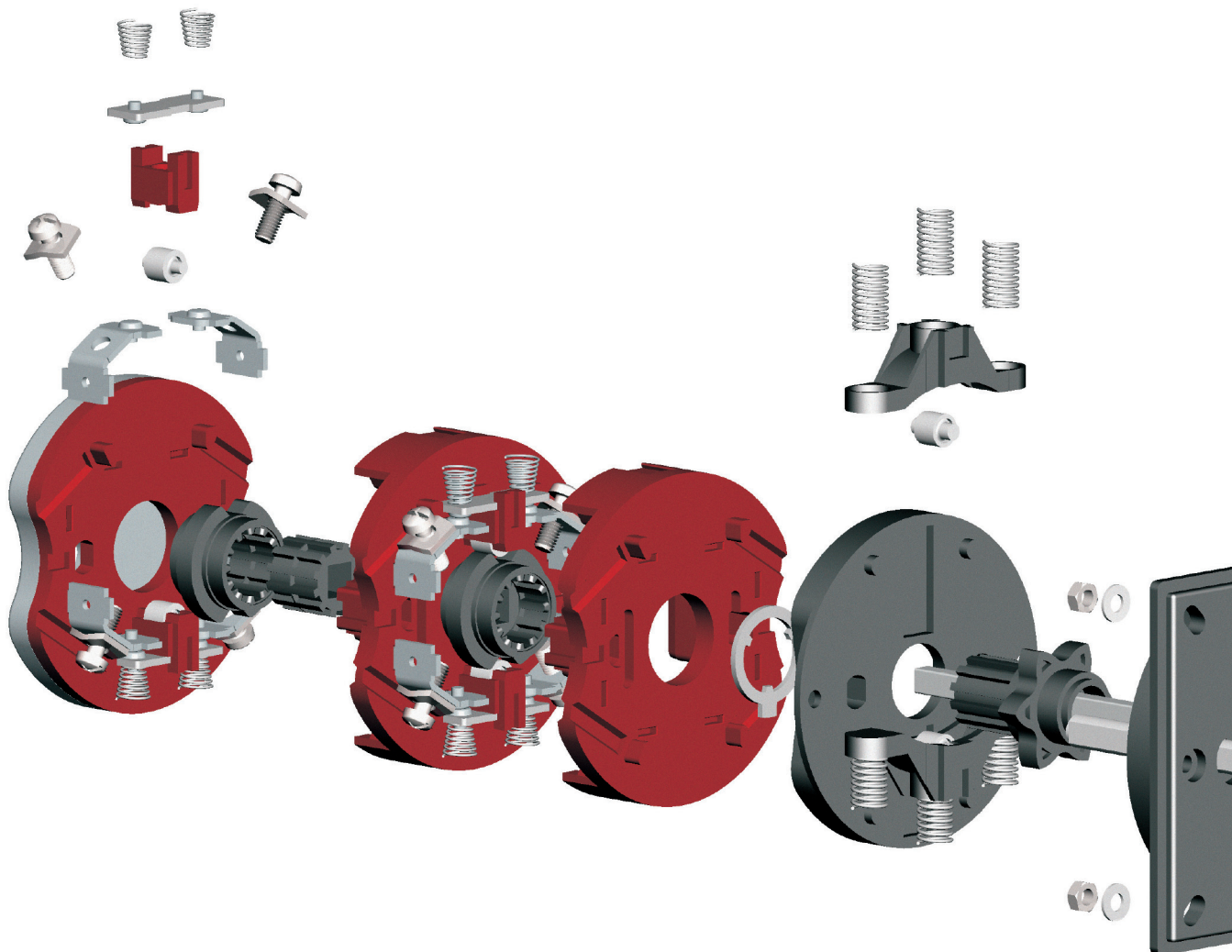

STRANA
PAGE

SADRŽAJ	1	CONTENTS
OPĆENITO	2	GENERAL
STANDARDNI OBLICI UGRADNJE UGRADNE VELIČINE	3	STANDARD MOUNTING FORMS MOUNTING SIZES
MJERNE SKICE	4-5	DIMENSIONAL DRAWINGS
POSEBNE IZVEDBE	6-10	OPTIONAL EXTRAS
TEHNIČKI PODACI	11	TECHNICAL DATA
STANDARDNI SKLOPNI PROGRAM	12-13	STANDARD SWITCHING PROGRAMME
MJERNE SKICE ZA POSEBNE IZVEDBE	14-19	DIMENSIONAL DRAWINGS FOR OPTIONAL EXTRAS
NARUDŽBENI KOD	20	ORDERING CODE
NARUDŽBENI LIST ZA SPECIJALNE SKLOPKE	21	ORDER SHEET FOR SPECIAL SWITCHES

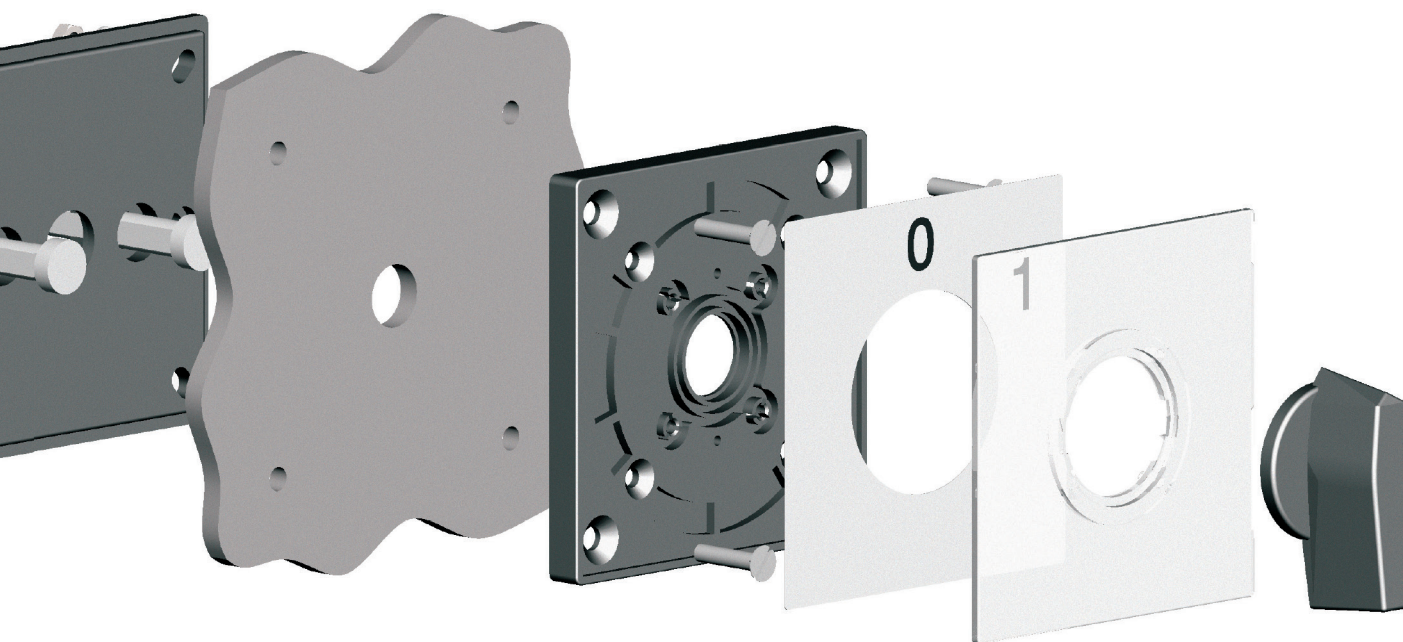

GREBENASTE SKLOPKE serije 4G

Grebenaste sklopke serije 4G razvijene su prema suvremenim principima i dostignućima na području sklopnih aparata uz upotrebu najkvalitetnijih izolacijskih materijala i kontakata od srebrnih legura. Odlikuju se visokim sklopnim moćima, električnom i mehaničkom trajnošću, izdržljivošću na kratkotrajno preopterećenje, a u kombinaciji s osiguračima i velikom otpornošću na dinamičke struje kratkog spoja.

Grebenaste sklopke imaju višestruku primjenu za sklapanje u glavnim i pomoćnim strujnim krugovima:

- kao **motorske sklopke** mogu sigurno sklapati, upravljati i pokretati trofazne i jednofazne motore, a mogu se izvesti kao: preklopka zvijezda - trokut, preklopka za reverziranje, preklopka za motore s više brzina itd.
 - u pomoćnim strujnim krugovima sastavljaju se prema željenom programu sklapanja: **sklopke za komandne, signalizacijske i mjerne krugove**
 - sklopke, preklopke i stepenaste sklopke** npr. za transformatore i aparate za zavarivanje
 - grupne sklopke** npr. za sklapanje otpornika i grijača
 - zakretna tipkala** s automatskim povratom
- Grebenaste sklopke serije 4G udovoljavaju propisima

IEC 60947, IEC 204, VDE 0660, VDE 0630, kao i mnogim nacionalnim propisima.

Tijelo sklopnog elementa izrađeno je od umjetne mase na bazi melamina koja je osobito otporna prema kliznim strujama i djelovanju električnog luka. Primjenom dvostrukog prekidanja i kontaktnih elemenata platiniranih specijalnom srebrnom legurom, otpornom na nagaranje uslijed električnog luka, postiže se velika sklopna moć i električna trajnost.

Sklopke se standardno sastavljaju do najviše 12 sklopnih elemenata. Na poseban zahtjev isporučujemo i sklopke sa više od 12 sklopnih elemenata. Sklopke 4G400 do 4G1200 izrađuju se paralelnim spajanjem kontakata sklopke 4G200. Sklopka se može izvesti prema želji sa slijedećim kutom zakreta:

Veličina	A0	A1	A2	A3	Max. broj položaja
Kut	30°	•	•	•	12
	45°	•	•	•	8
Zakreta	60°	•	•	•	6
	90°	•	•	•	4

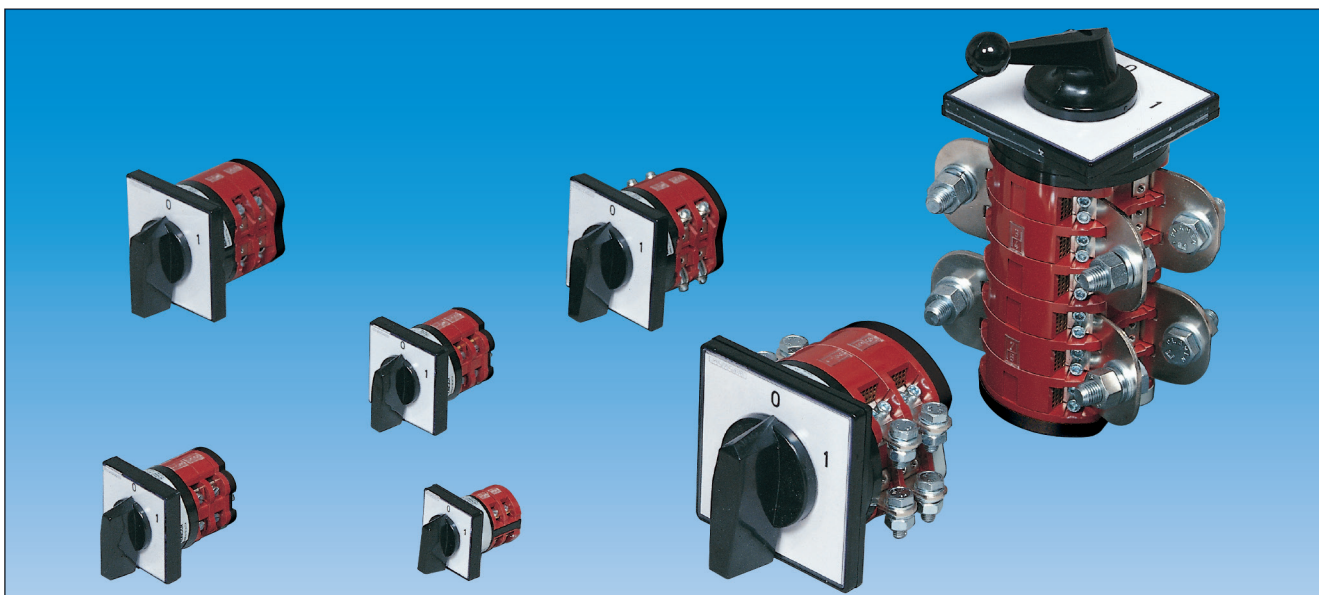

ROTARY CAM SWITCHES series 4G

Rotary cam switches 4G series have been developed to the new achievements in the field of switching devices through the application of high quality insulation materials and contacts made with silver alloys. Their advantages are: high making and breaking capacities, electrical and mechanical endurance. They can withstand short time overload and in combination with fuses are highly resistant to short circuit peak currents.

The rotary cam switches are intended for multiple switching operations in main as well as in auxiliary circuits:

- as **motor switches** they are designed for direct-online starting and stopping of single-phase and three-phase motors. They also come out as star-delta switches, reversing switches, pole-change over motor switches
 - in auxiliary circuits they are assembled in compliance with the switching programme according to preference: **switches for control, signalling and measuring circuits**
 - switches, selector switches and step switches** e.g. for transformers and welding apparatuses
 - group switches** e.g. for switching operations of resistors and heaters
 - twisted switch** with automatic return
- Rotary cam switches 4G series are built in accordance with the

following standards IEC 60947, IEC 204, VDE 0660, VDE 0630, as well as many other national standards.

The switching element's body is made of melamine-based material exceptionally resistant to leakage currents and effect of electric arc. By the application of double pole breaking and contact elements plated with a special silver alloy resistant to the electric arc, the switches of high breaking capacities and electric durabilities are obtained.

Standard switch can have maximum twelve switching elements. At special request the switches consisting of more than 12 elements may be supplied. The switches ranged from 4G400 up to 4G1200 are made by parallel connected contacts of the switch 4G200. The switch can be executed, as it is desired, with the following turning angle:

Switch size	A0	A1	A2	A3	max. possible number of positions
Turning angle	30°	•	•	•	12
	45°	•	•	•	8
	60°	•	•	•	6
	90°	•	•	•	4

STANDARDNI OBLICI UGRADNJE / STANDARD MOUNTING FORMS

OBLIK UGRADNJE MOUNTING FORM	OZNAKA MARKING	ZAŠTITA / PROTECTION		TIP TYPE	VELI- ČINA SIZE	IZGLED OUTLOOK
		PREDNJA FRONT	STRAŽNJA REAR			
Ugradna sklopka <i>Front mounting</i>	U	IP 40	IP 00	4G10	A0	
				4G16	A1	
				4G25	A1	
				4G40	A2	
				4G63	A2	
				4G80	A2	
Sklopka za odvojenu ugradnju <i>Rear mounting</i>	O	IP 40	IP 00	4G100	A3	
				4G200	A3	
				4G400	A3	
				4G630	A3	
				4G800	A3	
				4G1200	A3	
Sklopka u plastičnom kućištu <i>Switch in plastic casing</i>	P	IP 54	IP 54	4G10	A0	
				4G16	A1	
				4G25	A1	
				4G40	A2	
				4G63	A2	
				4G80	A2	
Sklopka u limenom kućištu <i>Switch in steel casing</i>	L	IP 54	IP 54	4G100	A3	
				4G200	A3	
				4G400	A3	
				4G630	A3	

UGRADBENE VELIČINE / MOUNTING SIZES

A0	A1		A2			A3		
4G10	4G16	4G25	4G40	4G63	4G80	4G100	4G400	4G800
						4G200	4G630	4G1200

MJERNA SKICA / DIMENSIONAL DRAWING (mm)

U - Ugradna sklopka / *Front mounting*

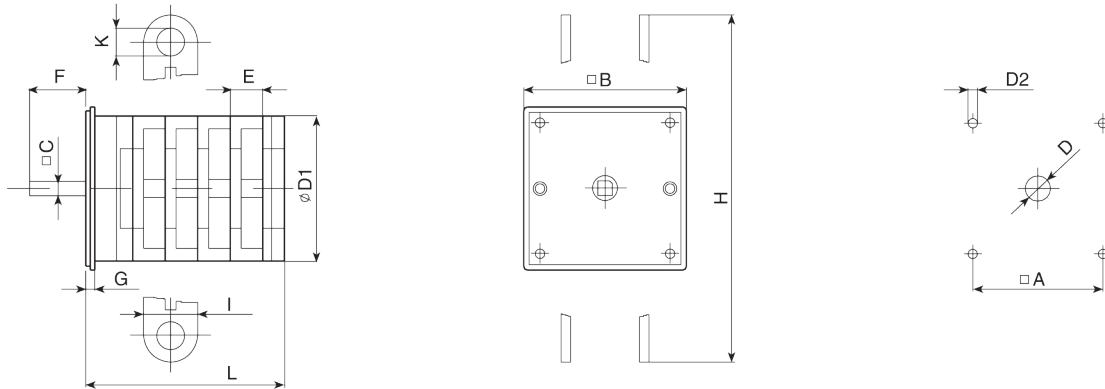
 Plan bušenja / *Drilling plan*

TIP / TYPE	OZNAKA / MARKING											BROJ ELEMENATA L NUMBER OF ELEMENTS												
	□A	□B	□C	ØD	ØD1	ØD2	E	F	G	H	I	ØK	1	2	3	4	5	6	7	8	9	10	11	12
4G10	36	48	6	12	38	4,3	9,6	22	2,5	-	-	-	32,5	42,1	51,7	61,3	70,9	80,5	90,1	99,7	109,3	118,9	128,5	138,1
4G16	48	65	7	14	58,5	4,3	13,5	26	5,5	-	-	-	41	54,5	68	81,5	95,5	109	122,5	136	149,5	163,5	177	190,5
4G25	48	65	7	14	58,5	4,3	13,5	26	5,5	-	-	-	41	54,5	68	81,5	95,5	109	122,5	136	149,5	163,5	177	190,5
4G40	68-72	90	8	14	80	5,3	18	31	5	-	-	-	56,5	74,5	92,5	110,5	128,5	146,5	164,5	182,5	200,5	218,5	236,5	254,5
4G63	68-72	90	8	14	80	5,3	18	31	5	-	-	-	56,5	74,5	92,5	110,5	128,5	146,5	164,5	182,5	200,5	218,5	236,5	254,5
4G80	68-72	90	8	14	80	5,3	18	31	5	-	-	-	56,5	74,5	92,5	110,5	128,5	146,5	164,5	182,5	200,5	218,5	236,5	254,5
4G100	104	132	10	16	120	5,3	29	37,5	6	140	20	10,5	77	107	136	166	196	226	284	314	343	373	402	432
4G200	104	132	10	16	120	5,3	29	37,5	6	140	20	10,5	77	107	136	166	196	226	284	314	343	373	402	432
4G400	104	132	10	16	120	5,3	29	37,5	6	170	45	13	-	107	-	166	-	226	-	314	-	373	-	432
4G630	104	132	10	16	120	5,3	29	37,5	6	190	74	17,5	-	-	136	-	226	-	-	-	343	-	-	432
4G800	104	132	10	16	120	5,3	29	37,5	6	260	50	17,5	-	107	-	166	-	226	-	314	-	373	-	432
4G1200	104	132	10	16	120	5,3	29	37,5	6	260	80	17,5	-	-	136	-	226	-	-	-	343	-	-	432

* - Za grupu A3 (4G100 do 4G1200), kada je broj elemenata veći od 6 pogledaj mjernu skicu sa dva razdjelna uređaja. (str. 14)
 For the switches size A3 (4G100 to 4G1200) with 7 and more elements see the dimensional drawing with two distribution devices. (page 14)

O - Sklopka za odvojenu ugradnju / *Rear mounting*

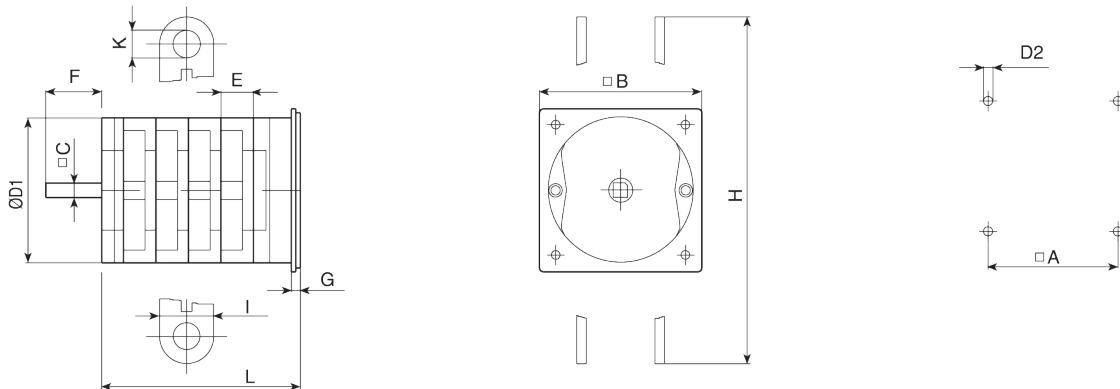
 Plan bušenja / *Drilling plan*

** Plan bušenja prednje ploče kao kod ugradne sklopke (U)
 Drilling plan of front panel as at front mounting switches (U)

TIP / TYPE	OZNAKA / MARKING											BROJ ELEMENATA L NUMBER OF ELEMENTS												
	□A	□B	□C	ØD	ØD1	ØD2	E	F	G	H	I	ØK	1	2	3	4	5	6	7	8	9	10	11	12
4G10	36	48	6	12	38	4,3	9,6	32	2,5	-	-	-	37,5	47,1	56,7	66,3	75,9	85,5	95,1	104,7	114,	123,9	133,5	143,1
4G16	48	65	7	14	58,5	4,3	13,5	36	5,5	-	-	-	46	59,5	73	86,5	100,5	114	127,5	141	154,5	168,5	182	195,5
4G25	48	65	7	14	58,5	4,3	13,5	36	5,5	-	-	-	46	59,5	73	86,5	100,5	114	127,5	141	154,5	168,5	182	195,5
4G40	68-72	90	8	14	80	5,3	18	40	5	-	-	-	56,5	74,5	92,5	110,	128,5	146,5	164,5	182,5	200,5	218,5	236,5	254,5
4G63	68-72	90	8	14	80	5,3	18	40	5	-	-	-	56,5	74,5	92,5	110,	128,5	146,5	164,5	182,5	200,5	218,5	236,5	254,5
4G80	68-72	90	8	14	80	5,3	18	40	5	-	-	-	56,5	74,5	92,5	110,5	128,5	146,5	164,5	182,5	200,5	218,5	236,5	254,5
4G100	104	132	10	16	120	5,3	29	50	6	140	20	10,5	77	107	136	166	196	226	284	314	343	373	402	432
4G200	104	132	10	16	120	5,3	29	50	6	140	20	10,5	77	107	136	166	196	226	284	314	343	373	402	432
4G400	104	132	10	16	120	5,3	29	50	6	170	45	13	-	107	-	166	-	226	-	314	-	373	-	432
4G630	104	132	10	16	120	5,3	29	50	6	190	74	17,5	-	-	136	-	226	-	-	-	343	-	-	432
4G800	104	132	10	16	120	5,3	29	50	6	260	50	17,5	-	107	-	166	-	226	-	314	-	373	-	432
4G1200	104	132	10	16	120	5,3	29	50	6	260	80	17,5	-	-	136	-	226	-	-	-	343	-	-	432

MJERNA SKICA / DIMENSIONAL DRAWING (mm)

P - Sklopka u plastičnom kućištu / Switch in plastic casing

Plan bušenja / Drilling plan

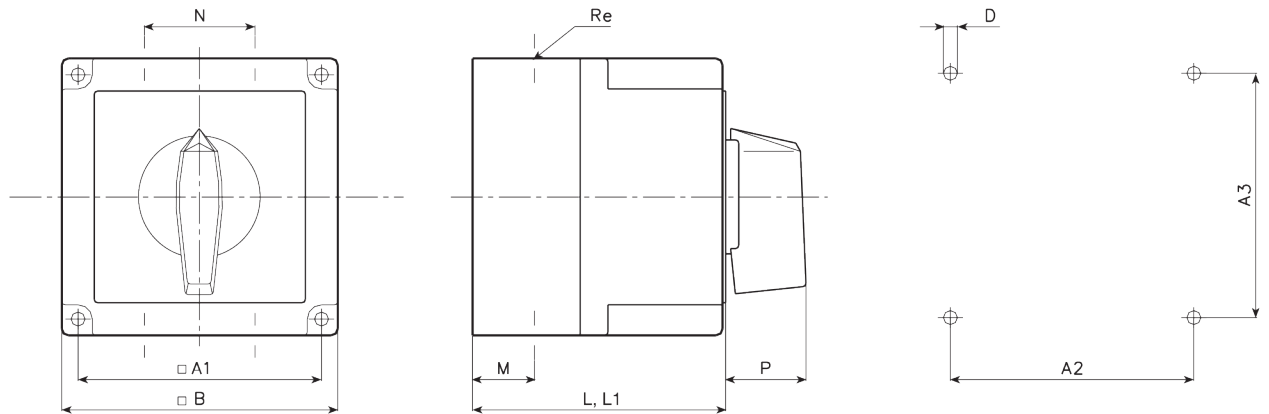

TIP / TYPE	TIP KUĆIŠTA HOUSING SIZE	BROJ ELEMENATA NUMBER OF ELEMENTS		L	L1	A1	A2	A3	B	D	M	N	P	ZAŠTITA PROTECTION	Re UVODNICE CONDUIT ENTRIES
		L	L1												
4G10	64 x 64	1 - 2	3 - 4	55,5	75	55	54	38	64	4,3	13	25	19	IP54	4 x Pg 11
	75 x 75	1 - 2	3 - 4	57,5	79,8	55	64	50	75	4,5	14	28	19	IP65	4 x Pg 13,5
4G16 4G25	85 x 85	1 - 2	3 - 4	77	104	75	75	75	85	4,3	19	34	25	IP54	4 x Pg 16
4G40 4G63 4G80	120 x 120	1 - 2	3 - 4	95	132	109	107	91	120	5,3	29	45	32	IP54	4 x Pg 21

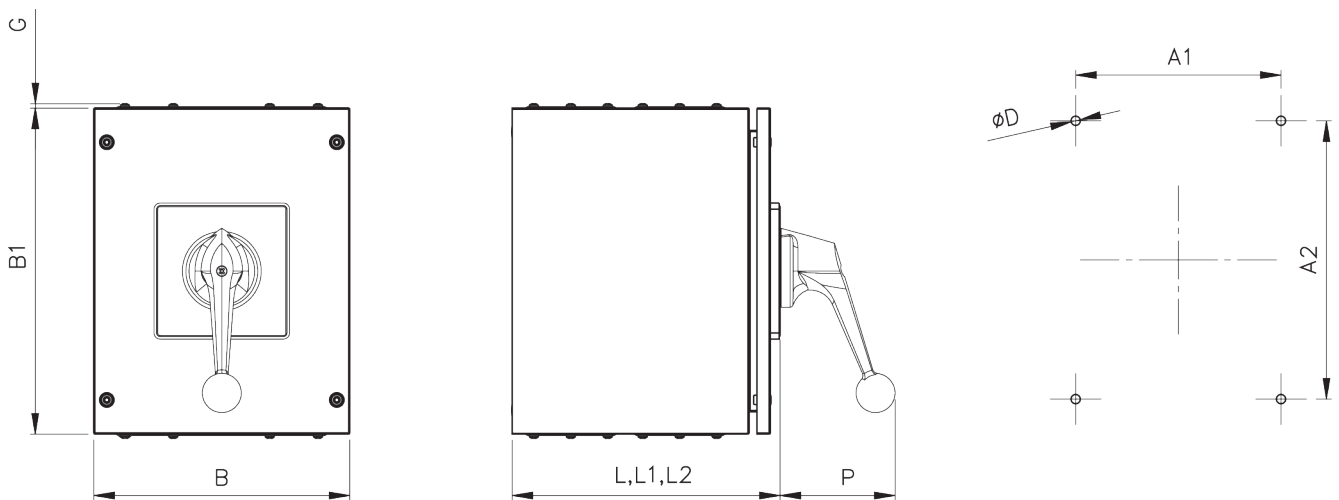

L - Sklopka u limenom kućištu / Switch in steel casing

Plan bušenja / Drilling plan



TIP / TYPE	TIP KUĆIŠTA HOUSING SIZE	BROJ ELEMENATA NUMBER OF ELEMENTS			L	L1	L2	A1	A2	B	B1	D	G	P
		L	L1	L2										
4G100 4G200	250 x 316	1 - 3	-	4 - 6	162	-	252	200	270	250	316	9	4,5	98
4G400 4G630	316 x 500	2 3	4 -	6 6	162	192	252	240	420	316	500	9	4,5	98

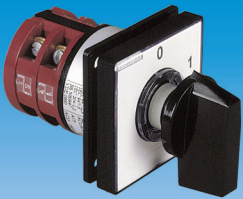
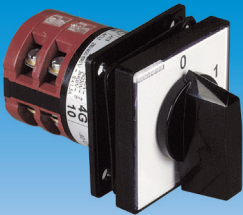
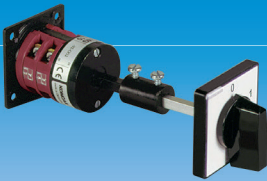
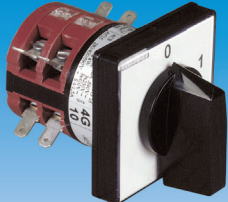

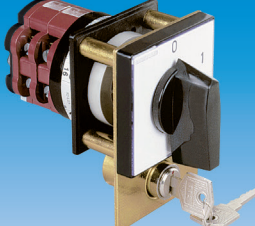

POSEBNE IZVEDBE / OPTIONAL EXTRAS

OPIS / DESCRIPTION	KOD / CODE				IZGLED / OUTLOOK	
	1	2	ILI/OR	4		
POVEĆANI STUPANJ ZAŠTITE INCREASED PROTECTION DEGREE						
Zaštita sprijeda IP54 <i>Front protection IP54</i>	4G40	-	- U O	01	
	4G63	-	- U O	01	
	4G80	-	- U O	01	
	4G100	-	- U O	01	
	4G200	-	- U O	01	
	4G400	-	- U O	01	
	4G630	-	- U O	01	
	4G800	-	- U O	01	
4G1200	-	- U O	01		
Zaštita sprijeda IP65 <i>Front protection IP65</i>						
Zaštita sprijeda IP65 <i>Front protection IP65</i>	4G10	-	- U O	51	
	4G16	-	- U O	51	
	4G25	-	- U O	51	
PRODUŽENA OSOVINA EXTENDED SHAFT						
Narudžbom je potrebno definirati dubinu ormara <i>It is necessary to define the board depth</i>	4G10	-	- O	02	
	4G16	-	- O	02	
	4G25	-	- O	02	
	4G40	-	- O	02	
	4G63	-	- O	02	
	4G80	-	- O	02	
	4G100	-	- O	02	
	4G200	-	- O	02	
UTIČNI PRIKLJUČCI FAST-ON TERMINALS						
Utični priključci AMP 4,8 4G10 AMP 6,3 4G16; 4G25 <i>Fast-on terminals</i>	4G10	-	- U O P	03	
	4G16	-	- U O P	03	
	4G25	-	- U O P	03	
POMOĆNI KONTAKTI AUXILIARY CONTACTS						
Narudžbom je potrebno definirati tip i program sklapanja pomoćnih kontakata <i>It is necessary to define switch type and switching diagram of the auxiliary contacts</i>	4G100	-	- U	04	
	4G200	-	- U	04	
	4G400	-	- U	04	
	4G630	-	- U	04	
	4G800	-	- U	04	
	4G1200	-	- U	04	
SKLOPKE SA ZAKLJUČAVANJEM SWITCHES WITH LOCKING						
Standardno zaključavanje u "0"- moguće i u drugim položajima (potrebno definirati). Ključ se vadi samo u zaključanom položaju. <i>In a standard manner locking is in "0"-possible in other positions, too (please define). The key can be pulled out only in locked position.</i>	4G16	-	- U	05	
	4G25	-	- U	05	
	4G40	-	- U	05	
	4G63	-	- U	05	
	4G80	-	- U	05	
	4G100	-	- U	05	
	4G200	-	- U	05	
	4G400	-	- U	05	
	4G630	-	- U	05	
	4G800	-	- U	05	
4G1200	-	- U	05		



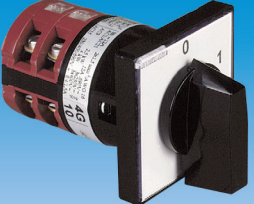
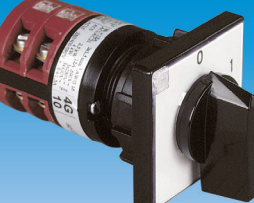

POSEBNE IZVEDBE / OPTIONAL EXTRAS

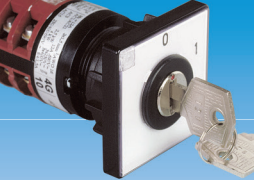
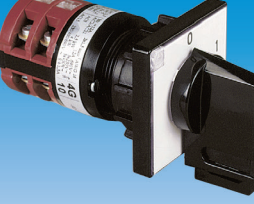
OPIS / DESCRIPTION	KOD / CODE				IZGLED / OUTLOOK			
	1	2	IL/OR	4				
<p>Zaključavanje samo u "0". Koristi se kod sklopki 0 - 1 (60°, 90°). Moguća upotreba (60°) sa većim brojem položaja (max. 6). Standardna izvedba - crna ručica, čeona ploča i prednja ploča. Specijalni zahtjev - siva boja ili crveno/žuta kombinacija boja</p> <p style="text-align: center;"> </p> <p><i>Locking only in "0". Used at switches 0 - 1 (60°, 90°). Possible use (60°) with several positions (max. 6). Standard version - black handle, cover plate and front panel. Special request - grey colour or red/yellow combination of colours.</i></p>	4G10	-	-	U O P	06	06	
	4G16	-	-	U O P	06		
	4G25	-	-	U O P	06		
	4G40	-	-	U O P	06		
	4G63	-	-	U O P	06		
	4G80	-	-	U O P	06		
<p>Zaključavanje samo u "0". Koristi se kod sklopki 0 - 1 (60°, 90°). Moguća upotreba (60°) sa većim brojem položaja (max. 6). Standardna izvedba - crna ručica, čeona ploča i prednja ploča. Specijalni zahtjev - siva boja ili crveno/žuta kombinacija boja</p> <p><i>Locking only in "0". Used at switches 0 - 1 (60°, 90°). Possible use (60°) with several positions (max. 6). Standard version - black handle, cover plate and front panel. Special request - grey colour or red/yellow combination of colours.</i></p>	4G100	-	-	U O L	06	06	
	4G200	-	-	U O L	06		
	4G400	-	-	U O L	06		
	4G630	-	-	U O L	06		
	4G800	-	-	U O L	06		
	4G1200	-	-	U O L	06		
<p>Zaključavanje (1-3 lokota) samo u "0".</p> <p><i>Locking (1-3 padlocks) only in "0".</i></p>	4G10	-	-	U O P	56	56	
<p>SPOJKA ZA VRATA DOOR COUPLING</p> <p>Otvaranje vrata u bilo kojem položaju (07) ili samo u "0" (08). Minimalna udaljenost od šarke je 150 mm.</p> <p><i>Door-opening in any position (07) or only in "0" (08). Minimal distance to the door-hinge is 150 mm.</i></p>	4G16	-	-	O	07/08	07 08	
	4G25	-	-	O	07/08		
	4G40	-	-	O	07/08		
	4G63	-	-	O	07/08		
	4G80	-	-	O	07/08		
	4G100	-	-	O	07/08		
	4G200	-	-	O	07/08		
	4G400	-	-	O	07/08		
	4G630	-	-	O	07/08		
	4G800	-	-	O	07/08		
	4G1200	-	-	O	07/08		
<p>Otvaranje vrata u bilo kojem položaju (57) ili samo u "0" (58). Minimalna udaljenost od šarke je 150 mm.</p> <p><i>Door-opening in any position (57) or only in "0" (58). Minimal distance to the door-hinge is 150 mm.</i></p>	4G10	-	-	O	57/58	57 58	
	4G16	-	-	O	57/58		
	4G25	-	-	O	57/58		
<p>Otvaranje vrata samo u "0" položaju. Minimalna udaljenost od šarke je 150 mm. Zaštita od slučajnog dodira priključnih stezaljki pod naponom za sklopke do dva elementa.</p> <p><i>Door-opening only in "0" position. Minimal distance to the door-hinge is 150 mm. Protection against an accidental contact with the supplying terminals under voltage for the switches with only two elements.</i></p>	4G10	-	-	O	68	68	
	4G16	-	-	O	68		
	4G25	-	-	O	68		

POSEBNE IZVEDBE / OPTIONAL EXTRAS

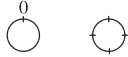
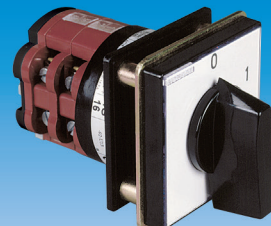
OPIS / DESCRIPTION	KOD / CODE					IZGLED / OUTLOOK
	1	2	ILI/OR	4		
CENTRALNA MONTAŽA CENTRAL MOUNTING						
Ugradnja u Ø30 mm (09) ili Ø22 mm (11). <i>Mounting into Ø30 mm (09) or Ø22 mm (11).</i>	4G10	-	- U	09/11	09 11 
Ugradnja u Ø22 mm odnosno Ø30 mm. Montaža s dva vijka. <i>Mounting into Ø22 mm or Ø30 mm with two screws.</i>	4G10	-	- U	20	20 
Brza ugradnja u Ø22 mm (36) ili Ø30 mm (37). <i>Quick mounting into Ø22 mm (36) or Ø30 mm (37).</i>	4G10	-	- U	36/37	36 37 
CENTRALNA MONTAŽA-ZAKLJUČAVANJE CENTRAL MOUNTING-LOCKING						
Ugradnja u Ø30 mm (10) ili Ø22 mm (12). Zaključavanje odnosno vađenje ključa pod 90°. Moguća 1-4 zaključana položaja unutar 360° (potrebno definirati). 	4G10	-	- U	10/12	10 12 
Brza ugradnja u Ø22 mm (29) ili Ø30 mm (30). Zaključavanje odnosno vađenje ključa pod 90°. Moguća 1-4 zaključana položaja unutar 360° (potrebno definirati). 	4G10	-	- U	29/30	29 30 
Brza ugradnja u Ø22 mm (41) ili Ø30 mm (42). Zaključavanje(1-3 lokota) u "0". <i>Quick mounting into Ø22 mm (41) or Ø30 mm (42). Padlocking (1-3) in "0".</i>	4G10	-	- U	41/42	41 42 

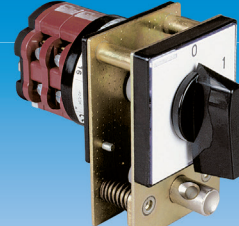
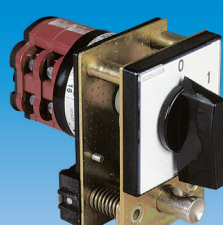
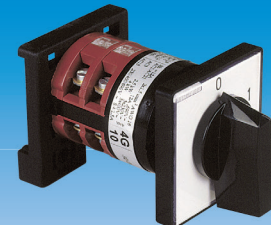
POSEBNE IZVEDBE / OPTIONAL EXTRAS

OPIS / DESCRIPTION	KOD / CODE					IZGLED / OUTLOOK	
	1	2	ILI/OR	4			
UTIČNI KLJUČ SOCKET KEY Utični ključ. Standardno vadenje ključa u "0". Na posebni zahtjev moguće i u drugim položajima pod 90°. <div style="text-align: center;">  </div> <i>Socket key. In a standard manner pull-out of the key in "0". Possible in other positions at the angle of 90° (please define).</i>	4G16 - - U 4G25 - - U 4G40 - - U 4G63 - - U 4G80 - - U				13	13	
SIGNALNE SVJETILJKE SIGNAL LAMPS Standardno ugrađena crvena svjetiljka (220V), desno dolje. Mogući naponi 110; 380V te i zelena boja svjetiljke (potrebno definirati). Na poseban zahtjev ugrađujemo i drugu svjetiljku lijevo dolje. <i>In a standard manner, the red lamp (220V) is built in the right bottom corner. Possible voltages are 110; 380V too and green lamp (please define). On special request second lamp can be built in left bottom corner.</i>	4G10 - - U O P 4G16 - - U O P 4G25 - - U O P 4G40 - - U O P 4G63 - - U O P 4G80 - - U O P 4G100 - - U O L 4G200 - - U O L 4G400 - - U O L 4G630 - - U O L 4G800 - - U O 4G1200 - - U O				15	15	
BLOKIRANJE POLOŽAJA BLOCKADE OF POSITIONS Blokiranje položaja-dvoručno upravljanje, protiv nehotećnog uklapanja (16), + zaključavanje jednim lokotom (26). <i>Blockade of positions-two hands operating, against an accidental switching-on (16), + locking by one padlock (26).</i>	4G16 - - U 4G25 - - U 4G40 - - U 4G63 - - U 4G80 - - U 4G100 - - U 4G200 - - U 4G400 - - U 4G630 - - U 4G800 - - U 4G1200 - - U				16/26	16/26	
Blokiranje položaja-dvoručno upravljanje, protiv nehotećnog uklapanja + pomoćni kontakti (17), + zaključavanje jednim lokotom (27). Upravljanje kontaktima ostvaruje se prije funkcije sklopke. <i>Blockade of positions-two hands operating, against an accidental switching-on + auxiliary contacts (17), + locking by one padlock (27). Operating of contacts is being realized before switch function.</i>	4G16 - - U 4G25 - - U 4G40 - - U 4G63 - - U 4G80 - - U 4G100 - - U 4G200 - - U 4G400 - - U 4G630 - - U 4G800 - - U 4G1200 - - U				17/27	17/27	
MONTAŽA NA ŠINU MOUNTING ON THE RAIL Montaža na šinu 35EN 50022 <i>Mounting on the rail 35EN 50022</i>	4G10 - - U O 4G16 - - U O 4G25 - - U O				18	18	
ZAŠTITNA KAPA PROTECTION COVER Zaštita od slučajnog dodira dovodnih priključnih stezaljki pod naponom, za sklopke sa samo dva elementa, u "0" položaju. <i>Protection against an accidental contact with the supplying terminals under voltage for the switches with only two elements, in "0" position.</i>	4G10 - - U O 4G16 - - U O 4G25 - - U O 4G40 - - U O 4G63 - - U O 4G80 - - U O				19	19	

POSEBNE IZVEDBE / OPTIONAL EXTRAS

OPIS / DESCRIPTION	KOD / CODE					IZGLED / OUTLOOK
	1	2	ILI/OR	4		
GLAVNA SKLOPKA MAIN SWITCH						
Zaključavanje (u "0") i zaštita od slučajnog dodira dovodnih priključnih stezaljki (max. 4 pol.). 23 - crna ručica i prednja ploča; 25 (ujedno i sklopka za nužno isklapanje) - crvena ručica i žuta prednja ploča.	4G16	- -	U		21/22	
Locking (in "0") and protection against an accidental contact with the supplying terminals (max. 4 pole.). 23 - black handle and front plate; 25 (with emergency) - red handle and yellow front plate.	4G25	- -	U		21/22	22
	4G40	- -	U		21/22	
	4G63	- -	U		21/22	22
	4G80	- -	U		21/22	
GLAVNA SKLOPKA MAIN SWITCH						
Zaključavanje (u "0") i zaštita od slučajnog dodira dovodnih priključnih stezaljki (max. 4 pol.). 23 - crna ručica i prednja ploča; 25 (ujedno i sklopka za nužno isklapanje) - crvena ručica i žuta prednja ploča.	4G10	- -	U	O P	23/25	
Locking (in "0") and protection against an accidental contact with the supplying terminals (max. 4 pole.). 23 - black handle and front plate; 25 (with emergency) - red handle and yellow front plate.	4G16	- -	U	O P	23/25	25
	4G25	- -	U	O P	23/25	
	4G40	- -	U	O P	23/25	25
	4G63	- -	U	O P	23/25	
	4G80	- -	U	O P	23/25	25
SKLOPKA ZA NUŽNO ISKLAPANJE EMERGENCY OFF SWITCH						
Standardna sklopka sa žutom prednjom pločom, žutom podlogom i crvenom ručicom (1-pol.: shema 90; 2-pol. shema 91; 3-pol. shema 10; 4-pol. shema 92).	4G10	- -	U	O P	24	24
Standard switch with yellow front plate, yellow escutcheon plate and red handle (1-pole: scheme 90; 2-pole: scheme 91; 3-pole: scheme 10; 4-pole: scheme 92).	4G16	- -	U	O P	24	
	4G25	- -	U	O P	24	24
	4G40	- -	U	O P	24	
	4G63	- -	U	O P	24	24
	4G80	- -	U	O P	24	
	4G100	- -	U	O	L 24	24
	4G200	- -	U	O	L 24	
	4G400	- -	U	O	L 24	24
	4G630	- -	U	O	L 24	
	4G800	- -	U	O	L 24	24
	4G1200	- -	U	O	L 24	
BLOKIRANJE SMJERA OKRETANJA BLOCKADE OF THE ROTATION DIRECTION						
Blokiranje lijevog smjera okretanja. The left direction is blocked.	4G10	- -	U	O P	28	
	4G16	- -	U	O P	28	28
	4G25	- -	U	O P	28	
	4G40	- -	U	O P	28	28
	4G63	- -	U	O P	28	
	4G80	- -	U	O P	28	28
INSTALACIONA KAPA SERVICE COVER						
Montaža na šinu 35EN 50022 s instalacionom kapom i ručicom za standardnu ugradnju u 45 mm. Podešavanje dužine L (izvedba 48). Fiksna dužina L (izvedba 48D). Snap on base mounting for track 35EN 50022. Both the service cover (45mm) and handle are adjustable in height (measure L - optional extra 48). Fixed measure L (optional extra 48D).	4G10	- -		O	48/ 48D	48 48D
Montaža na šinu 35EN 50022 sa instalacionom kapom i ključem za standardnu ugradnju u 45 mm. Snap on base mounting for track 35EN 50022. Both the service cover (45mm) and key are adjustable in height.	4G10	- -		O	49	

TEHNIČKI PODACI / TECHNICAL DATA

TIP SKLOPKE / SWITCH TYPE				4G10	4G16	4G25	4G40	4G63	4G80	4G100	4G200	4G400	4G630	4G800	4G1200		
Nazivni izolacijski napon <i>Rated insulation voltage</i>	IEC/VDE/BS	U_i	V	690	690	690	690	690	690	690	690	690	690	690	690		
Nazivni udarni podnosivi napon <i>Rated impulse withstand voltage</i>	(1) IEC-947 (III/3)	U_{imp}	kV	6	6	6	6	6	6	8	8	8	8	8	8		
Nazivna termička struja <i>Rated thermal current</i>	I_{th}	IEC/VDE/BS	A	12	20	25	50	63	80	125	200	400	630	800	1200		
Glavna sklopka (1) IEC-947 (III/3) Main switch	Najveća vrijednost nazivnog pogonskog napona <i>Max. value of rated operational voltage</i> Nazivni udarni podnosivi napon <i>Rated impulse withstand voltage</i>		V	480	480	480	690	690	690	690	690	690	690	690	690		
			kV	4	4	4	6	6	6	6	6	6	6	6	6	6	
Max. veličina osigurača za zaštitu od kratkog spoja <i>Max. fuse size for short circuit protection</i>	I_n (gG/gL)		10 kA	A	16	25	32	50	63	80	125	200	400	630	2x400	2x630	
			25 kA	A	10	25	32	50	63	80	125	160	315	500	2x400	2x500	
			50 kA	A	-	25	32	50	63	80	125	160	315	400	500	2x400	
			63 kA	A	-	25	25	36	50	63	100	100	250	355	400	630	
Nazivna kratkotrajno podnosiva struja <i>Rated short-time withstand current</i>	I_{cw}		1 sec	A	200	400	600	800	1000	1200	2600	3300	6500	9500	12000	18000	
			3 sec	A	120	250	400	530	800	900	1500	2000	3800	5700	7500	11500	
			10 sec	A	70	140	240	290	500	550	850	1100	2000	3000	4000	6100	
			30 sec	A	40	90	150	200	300	350	500	640	1200	1800	2400	3500	
			60 sec	A	30	70	120	150	200	250	350	460	850	1250	1600	2450	
Nazivna pogonska struja <i>Rated operational current</i>	I_c	AC1/AC21 IEC/VDE/BS	A	12	16	25	50	63	80	125	200	400	630	800	1200		
			110/120 V	A	10	20	25	50	63	72	-	-	-	-	-		
			220/230 V	A	8	20	20	40	50	50	-	-	-	-	-		
			380/400 V	A	4	10	10	40	45	45	-	-	-	-	-		
			660/690 V	A	1,5	2	2	10	10	10	-	-	-	-	-		
Motorska sklopka za kategoriju upotrebe <i>Motor switch in utilization category</i>	AC3/AC23 IEC/VDE/BS	220/230 V 380-415 V 500 V 660/690 V	3 faze	kW	2,5/3	4,5	7,5	12,5	18,5	21	27,5	27,5	27,5	27,5	27,5	27,5	
			3 faze	kW	4/6	8	13	21	32	37	47	47	47	47	47	47	
			3 faze	kW	5,5/7,5	11	15	27	42	45	62	62	62	62	62	62	
			3 faze	kW	5,5/7,5	11	15	27	45	45	-	-	-	-	-	-	
			1 faza, 2 pola	kW	0,8/0,8	1,3	1,7	3,6	4,5	6	-	-	-	-	-	-	
			1 faza, 2 pola	kW	1,5/1,7	2,6	4	7,2	10,6	12,1	-	-	-	-	-	-	
Sklopna moć kod istosmjernje struje Nazivna struja za 1 kontakt <i>DC Switching capacity</i> <i>Rated current 1 contact</i>	DC21A IEC/VDE/BS	24 V 48 V 60 V 110 V 220 V 440 V 600 V	24 V	A	12/12	20/20	25/25	50/50	63/63	80/80	100/100	200/200	-	-	-	-	
			48 V	A	12/12	20/20	25/25	50/50	63/63	80/80	100/100	200/200	-	-	-	-	
			60 V	A	12/12	20/16	20/16	50/40	63/40	80/40	100/100	200/200	-	-	-	-	
			110 V	A	4/1	5,5/3	5,5/3	15/3,5	15/3,5	15/3,5	35/7,5	35/7,5	-	-	-	-	
			220 V	A	0,70/0,4	0,8/0,4	0,8/0,4	1,2/0,4	1,2/0,4	1,2/0,4	2,5/0,75	2,5/0,75	-	-	-	-	
			440 V	A	0,25/0,15	0,5/0,25	0,5/0,25	0,6/0,25	0,6/0,25	0,6/0,25	0,9/0,3	0,9/0,3	-	-	-	-	
Potreban broj kontakata u seriju <i>Number of series contacts</i>	I_c (DC1)= I_{th}	24 V 60 V 110 V 220 V 440 V	24 V	Br.	1	1	1	1	1	1	1	1	-	-	-		
			60 V	Br.	1	1	1	1	1	1	1	1	-	-	-		
			110 V	No.	2	3	3	2	2	2	2	2	-	-	-		
			220 V	No.	5	4	4	3	4	4	3	4	-	-	-		
Mehanička trajnost <i>Mechanical durability</i>	Broj uklopa <i>Switching cycles</i>				3×10^6	3×10^6	3×10^6	1×10^6	1×10^6	1×10^6	2×10^5	2×10^5	2×10^5	2×10^5	2×10^5		
					3×10^6	3×10^6	3×10^6	1×10^6	1×10^6	1×10^6	2×10^5	2×10^5	2×10^5	2×10^5	2×10^5	2×10^5	
Priključni vijak <i>Terminal screw</i>			M	3	4	4	5	5	7	10	10	12	16	16	16		
Max. presjek vodiča <i>Max. conductor size</i>	Kruti vodič <i>Stranded wire</i>		mm ²	2x1,5	2x6	2x6	2x16	2x16	1x25	-	-	-	-	-	-		
			AWG	2x16	2x10	2x10	2x6	2x6	1x4	-	-	-	-	-	-		
	Finožičani vodič <i>Flexible wire</i>		mm ²	2x1,5	2x4	2x4	2x10	2x10	1x16	1x50 ⁽²⁾	1x95 ⁽²⁾	1x240 ⁽²⁾	-	-	-		
			AWG	2x16	2x12	2x12	2x8	2x8	1x6	1x1 ⁽²⁾	1x000 ⁽²⁾	1x500 ⁽²⁾	-	-	-		
Spojna traka <i>Flat connection</i>			mm	-	-	-	-	-	-	-	-	2x	2x	2x	2x		
													30x5	40x5	40x10	60x10	

(1) vrijedi za mreže sa uzemljenim zvjezdištem, prenaponska kategorija III, stupanj zagadenja 3
valid for neutral earthed systems, overvoltage category III, pollution degree 3

(2) kabela stopica
cable lug

STANDARDNI SKLOPNI PROGRAM / STANDARD SWITCHING PROGRAMME

SKLOPNI PROGRAM / SWITCHING PROGRAMME	BROJ SCHEME/ DIAGRAM No.	BROJ ELEMENATA/ No. OF ELEMENTS	KUT/ ANGLE
Sklopka / Switch			
1-polna/pole	90	1	60°
2-polna/pole	91	1	60°
3-polna/pole	10	2	60°
4-polna/pole	92	2	60°
5-polna/pole	99	3	60°
6-polna/pole	100	3	60°
Sklopka 90° / Switch 90°			
Kontakti 30° prethode/ Early-make contact 30° 1-polna/pole	270	1	90°
Kontakti 30° prethode/ Early-make contact 30° 2-polna/pole	271	1	90°
Kontakti 30° prethode/ Early-make contact 30° 3-polna/pole	63	2	90°
3 Kontakti 30° prethode/ 3 Early-make contact 30°			
1 Kontakti 60° prethode/ 1 Early-make contact 60° 4-polna/pole	272	2	90°
3 Kontakti 30° prethode/ 3 Early-make contact 30°			
2 Kontakti 60° prethode/ 2 Early-make contact 60° 5-polna/pole	273	3	90°
Kontakti 30° prethode/ Early-make contact 30° 6-polna/pole	274	3	90°
Sklopka s nul položajem/ Switch with off-position			
1-polna/pole	51	1	60°
2-polna/pole	52	2	60°
3-polna/pole	53	3	60°
4-polna/pole	75	4	60°
5-polna/pole	76	5	60°
6-polna/pole	77	6	60°
7-polna/pole	78	7	60°
8-polna/pole	79	8	60°
9-polna/pole	80	9	60°
10-polna/pole	81	10	60°
Sklopka bez nul položaja/ Switch without off-position			
1-polna/pole	54	1	90°
2-polna/pole	55	2	90°
3-polna/pole	56	3	90°
4-polna/pole	69	4	90°
5-polna/pole	70	5	90°
6-polna/pole	71	6	90°
7-polna/pole	72	7	90°
8-polna/pole	73	8	90°
9-polna/pole	74	9	90°
10-polna/pole	62	10	90°
Strujna preklopka, za preklapanje strujnih transformatora/ Current switch for switching of current transformers			
3-polna/pole	57	3	90°
Stepenasta sklopka s nul položajem/ Step switch with off-position			
1-polna/pole 2 Stepena/Two-step	107	1	60°
3 Stepena/Three-step	108	2	30°
4 Stepena/Four-step	109	2	30°
5 Stepena/Five-step	110	3	30°
6 Stepena/Six-step	111	4	30°
7 Stepena/Seven-step	112	4	30°
8 Stepena/Eight-step	113	5	30°
9 Stepena/Nine-step	114	5	30°
10 Stepena/Ten-step	115	6	30°
11 Stepena/Eleven-step	116	6	30°
2-polna/pole 2 Stepena/Two-step	123	2	60°
3 Stepena/Three-step	124	3	30°
4 Stepena/Four-step	125	4	30°
5 Stepena/Five-step	126	5	30°
6 Stepena/Six-step	127	7	30°
7 Stepena/Seven-step	128	8	30°
8 Stepena/Eight-step	129	9	30°
9 Stepena/Nine-step	130	10	30°
10 Stepena/Ten-step	131	11	30°
11 Stepena/Eleven-step	132	12	30°
3-polna/pole 2 Stepena/Two-step	135	3	60°
3 Stepena/Three-step	136	5	30°
4 Stepena/Four-step	137	6	30°

SKLOPNI PROGRAM / SWITCHING PROGRAMME	BROJ SCHEME/ DIAGRAM No.	BROJ ELEMENATA/ No. OF ELEMENTS	KUT/ ANGLE
5 Stepena/Five-step	138	8	30°
6 Stepena/Six-step	139	11	30°
7 Stepena/Seven-step	140	12	30°
4-polna/pole 2 Stepena/Two-step	145	4	60°
3 Stepena/Three-step	146	6	30°
4 Stepena/Four-step	147	8	30°
5 Stepena/Five-step	148	10	30°
5-polna/pole 2 Stepena/Two-step	151	5	60°
3 Stepena/Three-step	152	8	30°
4 Stepena/Four-step	153	10	30°
6-polna/pole 2 Stepena/Two-step	156	6	60°
3 Stepena/Three-step	157	9	30°
4 Stepena/Four-step	158	12	30°
7-polna/pole 2 Stepena/Two-step	160	7	60°
3 Stepena/Three-step	161	11	30°
8-polna/pole 2 Stepena/Two-step	163	8	60°
3 Stepena/Three-step	164	12	30°
Stepenasta sklopka bez nul položaja/ Step switch without off-position			
1-polna/pole 3 Stepena/Three-step	82	2	60°
4 Stepena/Four-step	83	2	60°
5 Stepena/Five-step	84	3	60°
6 Stepena/Six-step	85	3	60°
7 Stepena/Seven-step	101	4	30°
8 Stepena/Eight-step	102	4	30°
9 Stepena/Nine-step	103	5	30°
10 Stepena/Ten-step	104	5	30°
11 Stepena/Eleven-step	105	6	30°
12 Stepena/Twelve-step	106	6	30°
2-polna/pole 3 Stepena/Three-step	86	3	60°
4 Stepena/Four-step	87	4	60°
5 Stepena/Five-step	88	5	60°
6 Stepena/Six-step	89	6	60°
7 Stepena/Seven-step	117	7	30°
8 Stepena/Eight-step	118	8	30°
9 Stepena/Nine-step	119	9	30°
10 Stepena/Ten-step	120	10	30°
11 Stepena/Eleven-step	121	11	30°
12 Stepena/Twelve-step	122	12	30°
3-polna/pole 3 Stepena/Three-step	93	5	60°
4 Stepena/Four-step	94	6	60°
5 Stepena/Five-step	95	8	60°
6 Stepena/Six-step	96	9	30°
7 Stepena/Seven-step	133	11	30°
8 Stepena/Eight-step	134	12	30°
4-polna/pole 3 Stepena/Three-step	141	6	60°
4 Stepena/Four-step	142	8	60°
5 Stepena/Five-step	143	10	60°
6 Stepena/Six-step	144	12	60°
5-polna/pole 3 Stepena/Three-step	149	8	60°
4 Stepena/Four-step	150	10	60°
6-polna/pole 3 Stepena/Three-step	154	9	60°
4 Stepena/Four-step	155	12	60°
7-polna/pole 4 Stepena/Four-step	159	11	60°
8-polna/pole 4 Stepena/Four-step	162	12	60°
Grupna sklopka s nul položajem/ Group switch with off-position			
1-polna/pole 2 Grupe/Group	251	1	60°
3 Grupe/Group	254	2	30°
2-polna/pole 2 Grupe/Group	252	2	60°
3 Grupe/Group	255	3	30°
3-polna/pole 2 Grupe/Group	253	3	60°
3 Grupe/Group	256	5	30°
Serijsko grupna sklopka/ Series-connected group switch			
1-polna/pole 2 Grupe/Group	257	1	30°
2-polna/pole 2 Grupe/Group	258	2	30°
3-polna/pole 2 Grupe/Group	259	3	30°
Serijsko-paralelna sklopka/ Series parallel connected switch			
2-polna/pole 2 Grupe/Group	260	2	30°

STANDARDNI SKLOPNI PROGRAM / STANDARD SWITCHING PROGRAMME

SKLOPNI PROGRAM / SWITCHING PROGRAMME	BROJ SCHEME/ DIAGRAM No.	BROJ ELEMENATA/ No. OF ELEMENTS	KUT/ ANGLE	SKLOPNI PROGRAM / SWITCHING PROGRAMME	BROJ SCHEME/ DIAGRAM No.	BROJ ELEMENATA/ No. OF ELEMENTS	KUT/ ANGLE
Sklopke za mjerenje struje i napona/ Selector switches for measuring of current and voltage							
Ampermetarska preklapka/							
2-polna/pole L1-L2-L3	58	5	90°	Povrat iz Y u 0 s protustrujnim kočenjem/ Return from Y to 0 with Counter-current breaking	28	4	30° + 60°
2-polna/pole 0-1-2-3	97	6	90°	Povrat iz Y u 0/ Return from Y to 0	29	5	30° + 30° + 60°
1-polna/pole 0-1-2-3	98	4	90°	Kao naponska preklapka/ A voltage selector switch	30	4	60°
Voltmetarska preklapka bez nul položaja/ Voltmeter selector switch without off position				Za upravljanje sklopnikom/ For contactor control	31	4	90°
3 linijska napona + 1 fazni napon/ 3 phase-to-phase voltages + 1 phase-to-neutral voltage	60	3	90°	2 smjera okretanja/ 2 turning directions	21	5	30°
Voltmetarska preklapka s nul položajem/ Voltmeter selector switch with off position				Preklapka za motore u Dahlanderovom spoju/ Selector switch for motors in Dahlander connection			
3 fazna napona/ 3 phase-to-neutral voltage	68	2	30°	2 brzine Δ-0-YY/2 speed Δ-0-YY	13	4	60°
3 linijska napona/ 3 phase-to-phase voltages	67	2	30°	2 brzine 0-Δ-YY/2 speed 0-Δ-YY	19	4	60°
3 linijska napona + 3 fazna napona/ 3 phase-to-neutral voltages + 3 phase-to-phase voltages	66	3	30°	2 brzine, 2 smjera okretanja YY-Δ-0-Δ-YY/ 2 speed, 2 turning directions YY-Δ-0-Δ-YY	20	6	30°
ZAKRETNA TIPKALA/ TWIST SWITCHES				Za upravljanje sklopnikom/ For contactor control	32	5	60°
Preklapka s nul položaja/ Selector switch with off-position				Preklapka za motore s odjeljenim namotom/ Selector switch for motors with a separate winding			
Povrat u 0 iz oba položaja/ Return to 0 from both positions				1-0-2	53	3	60°
1-polna/pole 201	201	1	30°	0-1-2	22	3	60°
2-polna/pole 202	202	2	30°	2 smjera okretanja/ 2 turning directions	23	5	60°
3-polna/pole 203	203	3	30°	Za upravljanje sklopnikom/ For contactor control	33	4	60°
Preklapka bez nul položaja/ Selector switch without off-position				Preklapka za motore s tri brzine/ Selector switch for three-speed motors			
1 uklopni + 1 isklopni kontakt/ 1 make + 1 break contact	204	1	30°	2 namota 0-Δ-Y-YY (1-3 brzine Dahlanderov spoj)/ 2 windings 0-Δ-Y-YY (1 and 3 speed Dahlander connection)	34	6	30°
2 uklopna + 2 isklopna kontakta/ 2 make + 2 break contacts	205	2	30°	2 namota 0-Δ-YY-Y (1-2 brzine Dahlanderov spoj)/ 2 windings 0-Δ-YY-Y (1 and 2 speed Dahlander connection)	35	6	30°
3 uklopna + 3 isklopna kontakta/ 3 make + 3 break contacts	206	3	30°	2 namota 0-Y-Δ-YY (2-3 brzine Dahlanderov spoj)/ 2 windings 0-Y-Δ-YY (2 and 3 speed Dahlander connection)	36	6	30°
Za upravljanje sklopnikom 1-polna/ For contactor control 1-pole	207	1	30°	Reverziona preklapka/ Reversing switch			
1 uklopni + 1 isklopni kontakt kod zakreta lijevo i desno/ 1 make + 1 break contact turning to left and right	208	1	30°	2-polna/2-pole	24	2	60°
2 uklopna + 2 isklopna kontakta kod zakreta lijevo i desno/ 2 make + 2 break contacts turning to left and right	209	4	30°	2-polna, povrat u 0 položaj/ 2-pole, return to off position	25	2	30°
Kombinacija sklopke i tipkala/ Combination selector and twist switch	210	5	90° + 30°	3-polna/3-pole	11	3	60°
MOTORSKE SKLOPKE/ MOTOR SWITCHES				3-polna, povrat u 0 položaj/ 3-pole, return to off position	26	3	30°
Preklapka zvijezda trokut/ Star-delta selector switch				Za upravljanje sklopnikom/ For contactor control	27	5	90° + 30°
Osnovna izvedba/ Basic design	12	4	60°	Sklopka za upuštanje jednofaznih motora/ Switch for starting of single-phase motors	15	2	30° + 90°

MJERNE SKICE / DIMENSIONAL DRAWINGS (mm)

UGRADNJA SKLOPKE / MOUNTING OF THE SWITCH 4G100 - 4G1200

Za sklopku sa više od 6 elemenata / For the switch with more than 6 elements

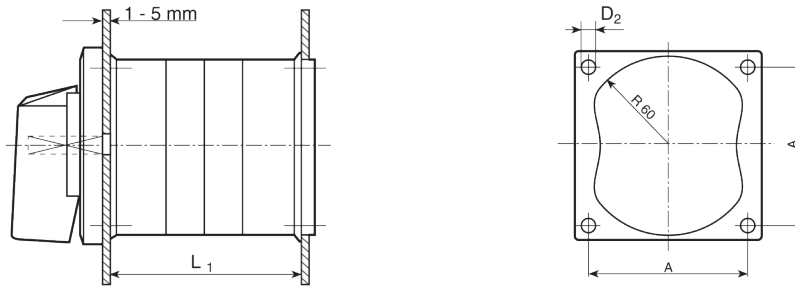

VELIČINA SIZE	A(mm)	D ₂ (mm) ∅	BROJ ELEMENATA / NO. OF ELEMENTS - L(mm)					
			7	8	9	10	11	12
A3	104	5,3	271	301	330	360	389	419

PREDNJI SKLOPOVI / FRONT PARTS

Prednja ploča / Front plate

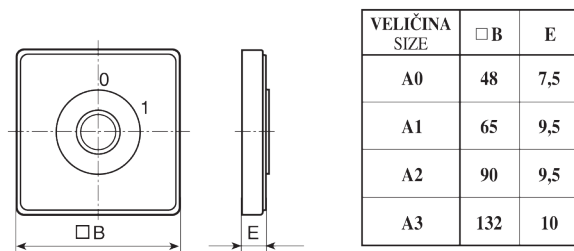

Prednja ploča s natpisom N / Front plate with the title N

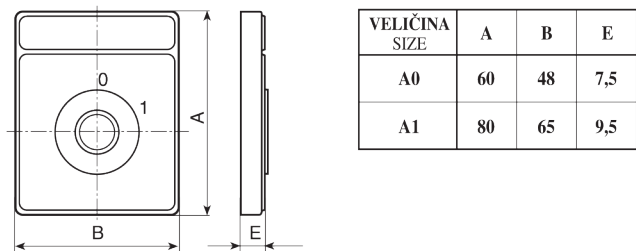

Ručice / Handles

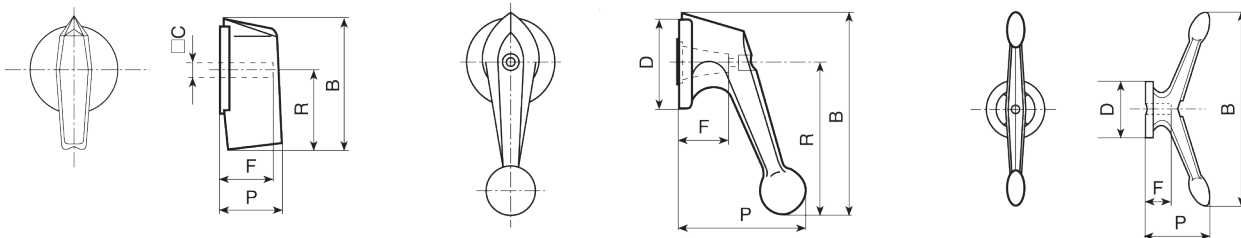

VELIČINA SIZE	C □	P	R	B	F
A0	6	19	23,5	39,5	16
A1	7	25	32	53	20
A2	8	32	43,5	70,5	26
A3	10	46,5	63,5	104	39

VELIČINA SIZE	D ∅	P	R	B	F
A1	35	51	61,5	81,5	15
A2	48	64	79,5	105,5	19
A3	75	88	115	155,5	28

VELIČINA SIZE	D ∅	P	B	F
A3	75	87	262	28

	BOJA / COLOUR	NARUŽBENI KOD / ORDERING CODE			
		VELIČINA / SIZE			
		A0	A1	A2	A3
	siva / gray crvena / red crna / black žuta / yellow	R011 R012 R014 R015	R111 - 7 R112 - 7 R114 - 7 R115 - 7	R211-8 R212-8 R214-8 R215-8	R311 R312 R314 R315
	siva / gray crvena / red crna / black žuta / yellow	- - - -	R121 - 7 R122 - 7 R124 - 7 R125 - 7	R221-8 R222-8 R224-8 R225-8	R321 R322 R324 R325
	siva / gray crvena / red crna / black žuta / yellow	- - - -	- - - -	- - - -	R331 R332 R334 R335

MJERNE SKICE / DIMENSIONAL DRAWINGS (mm)

05 - Zaključavanje ključem / *Locking with the key*

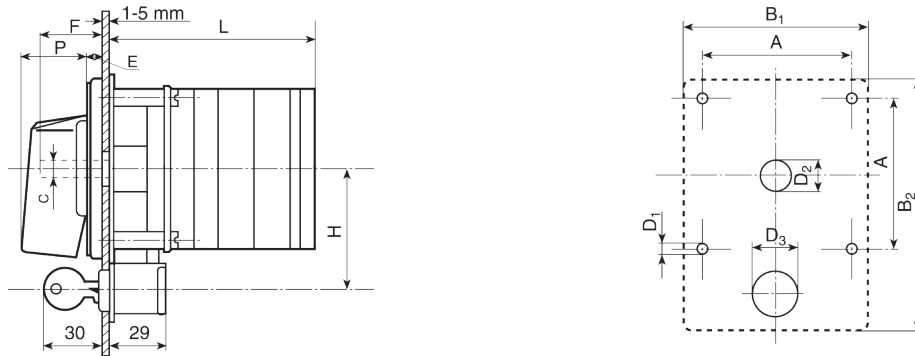

VELIČINA SIZE	D ₁ ∅	D ₂ ∅	D ₃ ∅	A	B ₁	B ₂	C □	E	F	H	P	BROJ ELEMENATA / NO. OF ELEMENTS - L(mm)											
												1	2	3	4	5	6	7	8	9	10	11	12
A1	5	14	21,5	48	65	98	7	9,5	26	48	25	67,5	81	94,5	108	121,7	135,5	149	162,5	176	190	203,5	217
A2	6	16	21,5	68-72	90	122	8	9,5	31	60	32	82,5	100,5	118,5	136,5	154,5	172,5	190,5	208,5	226,5	244,5	262,5	280,5
A3	6	18	21,5	104	132	168	10	10	37,5	85	46,5	103	133	162	192	222	252	310	340	369	399	428	458

06 - Zaključavanje (lokoti) - za sklopke / *Padlocking - for the switches 4G100 - 4G1200*

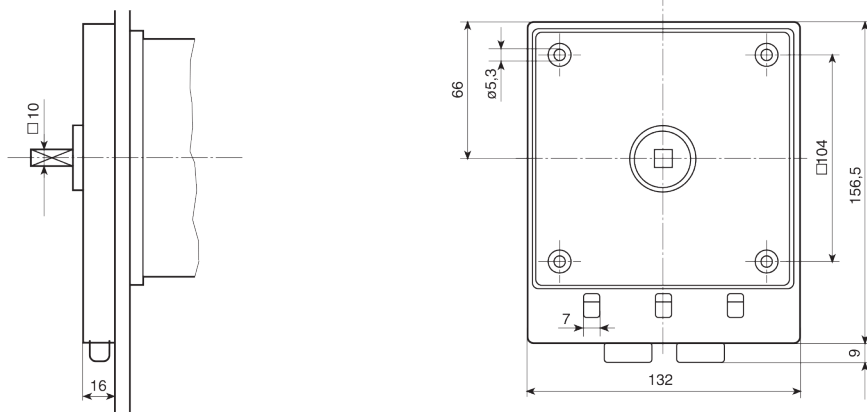

08 - Spojka za vrata s blokadom / *Door coupling with the blockade*

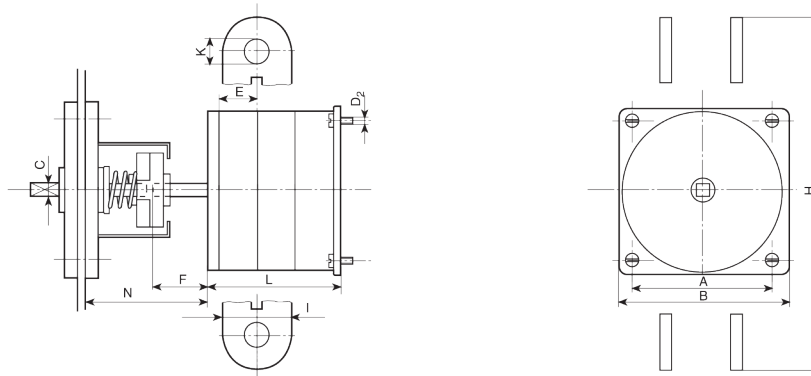

VELIČINA SIZE	D ₂ ∅	A □	B □	C □	E	F	H	I	K	min N*	BROJ ELEMENATA / NO. OF ELEMENTS - L(mm)											
											1	2	3	4	5	6	7	8	9	10	11	12
A1	4	48	65	7	13,5	26	-	-	-	64	46	59,5	73	86,5	100,5	114	127,5	141	154,5	168,5	182	195,5
A2	5	68-72	90	8	18	17	-	-	-	60	56,5	74,5	92,5	110,5	128,5	146,5	164,5	182,5	200,5	218,5	236,5	254,5
A3	5	104	132	10	29	30	**	**	**	77	77	107	136	166	196	226	284	314	343	373	402	432

* Veća mjera za kotu N je moguća na posebni zahtjev / *Longer measure for N is possible at special request*
 ** Mjere za H,I i K - vidi tabele na stranici 4 / *Figures for H,I and K - see the Tables on page 4*

MJERNE SKICE / DIMENSIONAL DRAWINGS (mm)

09 - Centralna ugradnja / Central mounting $\varnothing 30, 5$

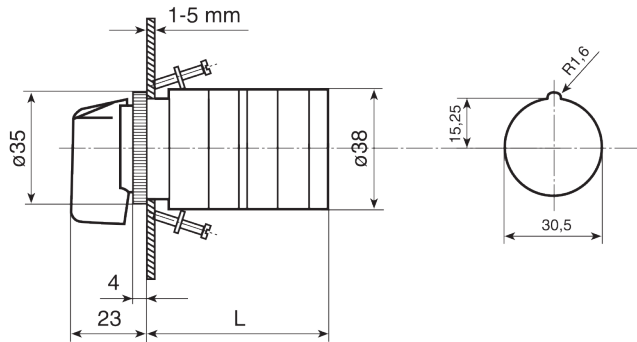

10 - Centralna ugradnja / central mounting $\varnothing 30, 5$ mm (zaključavanje/locking)

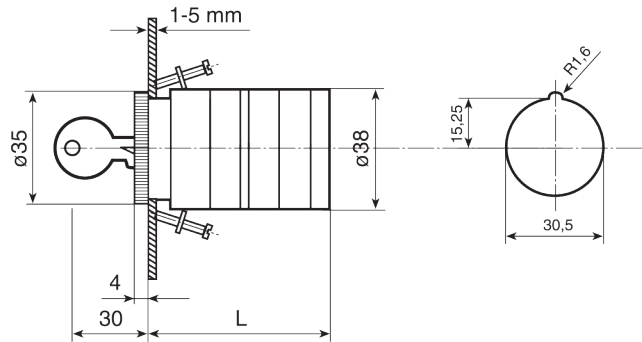

09, 10	BROJ ELEMENATA / NO. OF ELEMENTS - L(mm)											
	1	2	3	4	5	6	7	8	9	10	11	12
	47	56,5	66	75,5	85	95	104,5	114	123,5	133	143	152,5

11 - Centralna ugradnja / Central mounting $\varnothing 22, 5$ mm

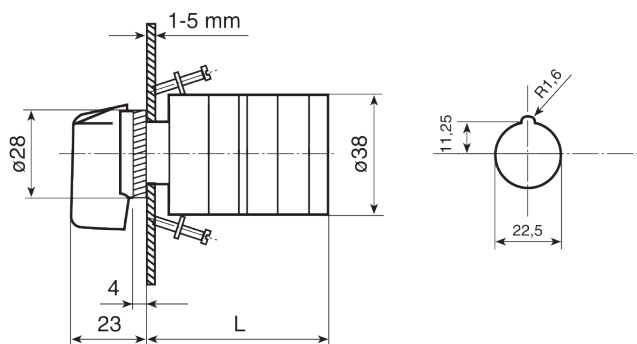

12 - Centralna ugradnja / Central mounting $\varnothing 22, 5$ mm (zaključavanje/locking)

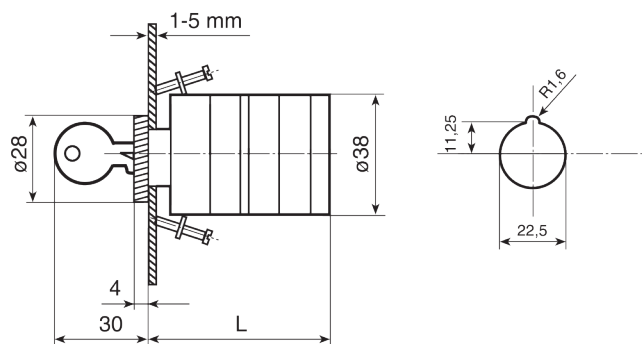

11, 12	BROJ ELEMENATA / NO. OF ELEMENTS - L(mm)											
	1	2	3	4	5	6	7	8	9	10	11	12
	47	56,5	66	75,5	85	95	104,5	114	123,5	133	143	152,5

15 - Sklopka sa signalnom lampom / Switch with signal lamp

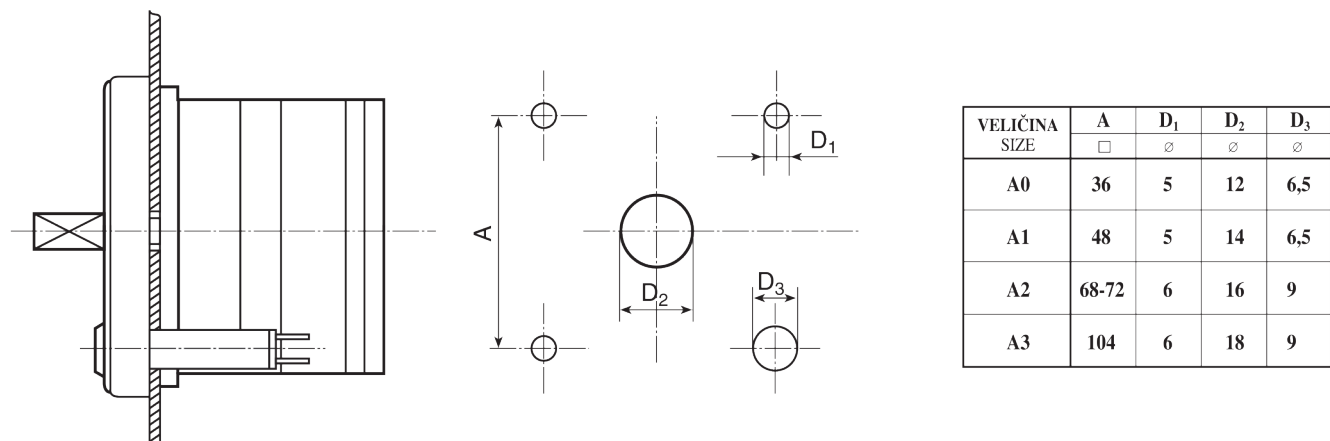

MJERNE SKICE / DIMENSIONAL DRAWINGS (mm)

16 - Blokiranje položaja / *Blockade of positions*

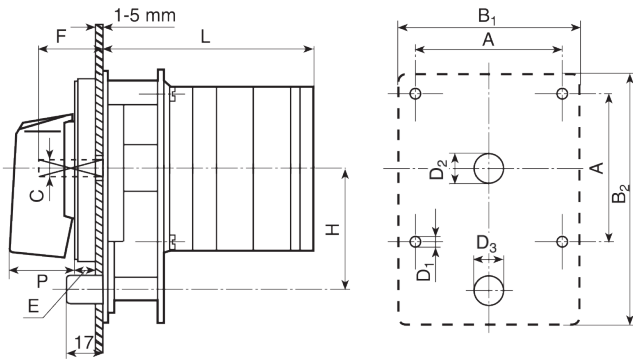

17 - Blokiranje položaja + tipkalo / *Blockade of positions + push button*

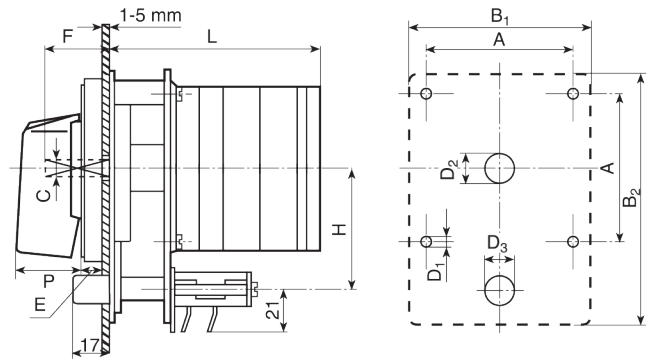

VELIČINA SIZE	D ₁ ∅	D ₂ ∅	D ₃ ∅	A	B ₁	B ₂	C □	E	F	H	P	BROJ ELEMENATA / NO. OF ELEMENTS - L(mm)											
												1	2	3	4	5	6	7	8	9	10	11	12
A1	5	14	15	48	65	98	7	9,5	26	48	25	69,5	83	96,5	110	124	137,5	151	164,5	178	192	205,5	219
A2	6	16	15	68-72	90	122	8	9,5	31	60	32	84,5	102,5	120,5	138,5	156,5	174,5	192,5	210,5	228,5	246,5	264,5	282,5
A3	6	18	15	104	132	168	10	10	37,5	85	46,5	105	135	164	194	224	254	312	342	371	401	430	460

18 - Montaža na šinu / *Mounting on the rail*

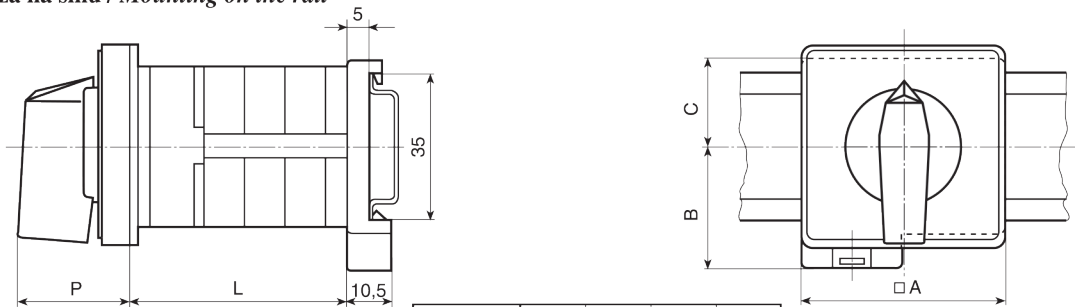

VELIČINA SIZE	A	B	C	P
A0	48	30	21	26,5
A1	65	38	20	34,5

19 - Zaštitna kapa / *Protection cover*

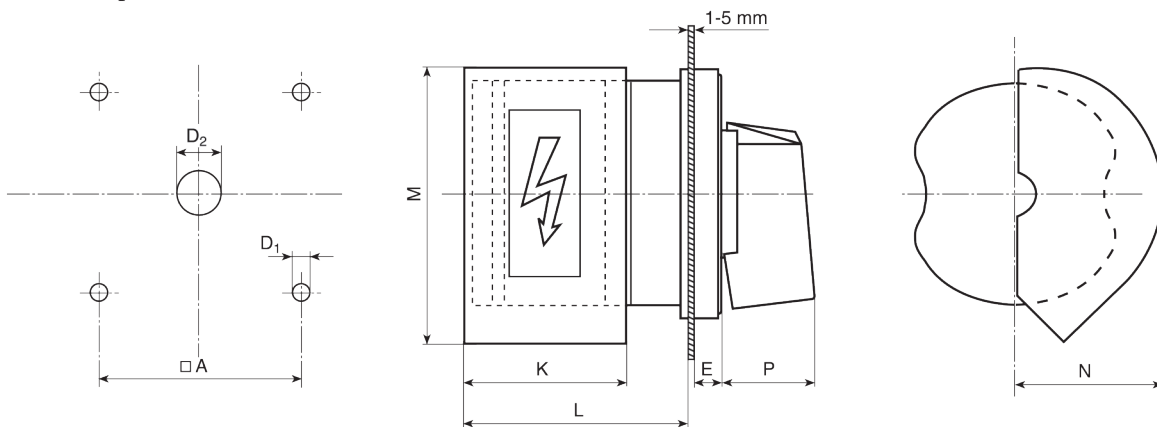

VELIČINA SIZE	D ₁ ∅	D ₂ ∅	A □	E	P	K	M	N	L
A0	5	12	36	7,5	19	43	64	30	48,5
A1	5	14	48	9,5	25	51	78	42	69
A2	6	16	68-72	9,5	32	58	99	53	78

MJERNE SKICE / DIMENSIONAL DRAWINGS (mm)

21, 22 - Glavna sklopka / Main switch

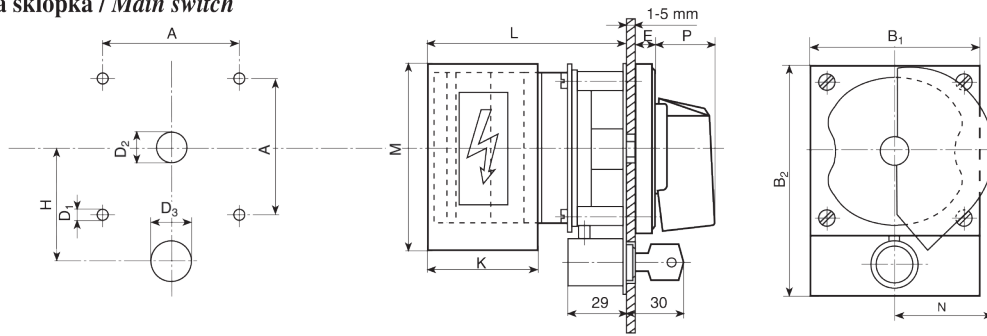

VELIČINA SIZE	D ₁	D ₂	D ₃	A	B ₁	B ₂	P	K	M	N	L	E	H
	∅	∅	∅										
A1	5	14	21,5	48	65	98	25	51	78	42	95	9,5	48
A2	6	16	21,5	68-72	90	122	32	58	99	53	104	9,5	60

23, 25 - Glavna sklopka / Main switch

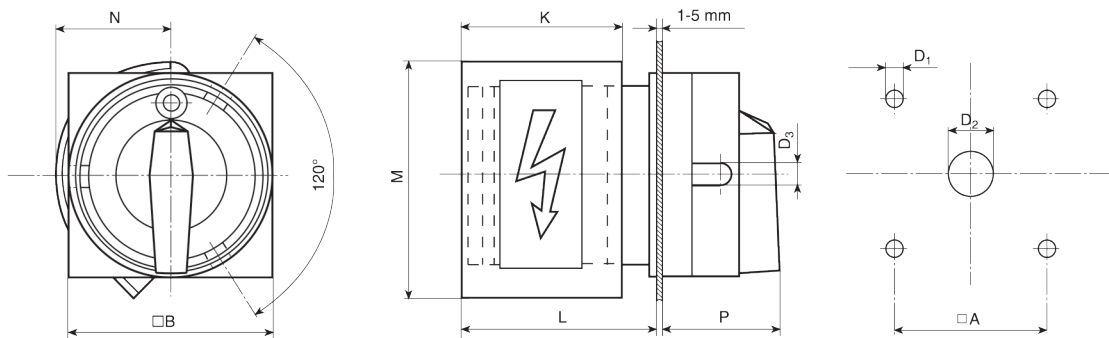

VELIČINA SIZE	D ₁	D ₂	D ₃	A	B	P	K	M	N	L
	∅	∅	∅	□	□					
A0	5	12	5	36	48	34	43	64	30	48,5
A1	5	14	6	48	65	38	51	78	42	69
A2	6	16	7	68-72	90	48,5	58	99	53	78

27 - Blokiranje položaja + tipkalo + zaključavanje / Blockade of positions + push button + locking

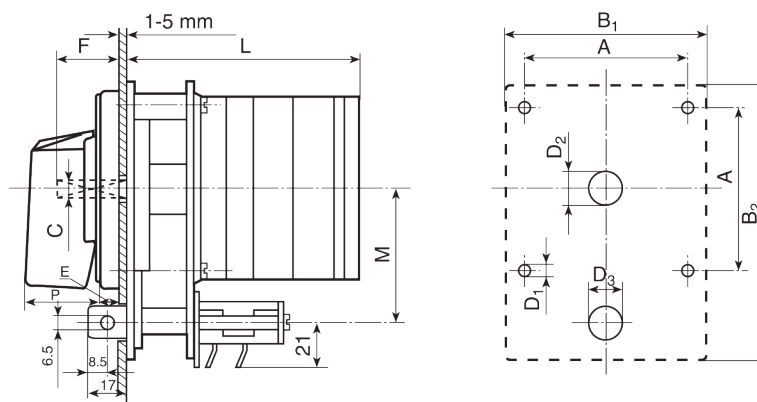

VELIČINA SIZE	D ₁	D ₂	D ₃	A	B ₁	B ₂	C	E	F	H	P	BROJ ELEMENATA / NO. OF ELEMENTS - L(mm)												
	∅	∅	∅									□	1	2	3	4	5	6	7	8	9	10	11	12
	A1	5	14									15	48	65	98	7	9,5	26	48	25	69,5	83	96,5	110
A2	6	16	15	68-72	90	122	8	9,5	31	60	32	84,5	102,5	120,5	138,5	156,5	174,5	192,5	210,5	228,5	246,5	264,5	282,5	
A3	6	18	15	104	132	168	10	10	37,5	85	46,5	105	135	164	194	224	254	312	342	371	401	430	460	

MJERNE SKICE / DIMENSIONAL DRAWINGS (mm)

29, 30 - Centralna ugradnja + zaključavanje + standardna prednja ploča / *Central mounting + locking + standard front plate*

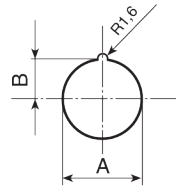
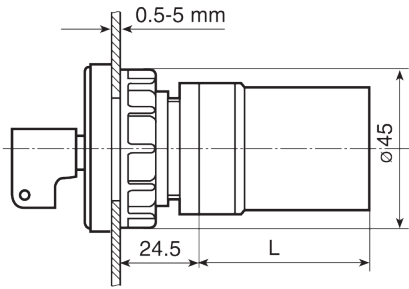

	A	B
29	22,5	11,25
30	30,5	15,25

BROJ ELEMENATA / NO. OF ELEMENTS	1	2	3	4	5	6	7	8	9	10	11	12
L(mm)	29	38,5	48	57,5	67	77	86,5	96	105,5	115	125	134,5

48, 48D, 49 - Instalaciona kapa / *Service cover*

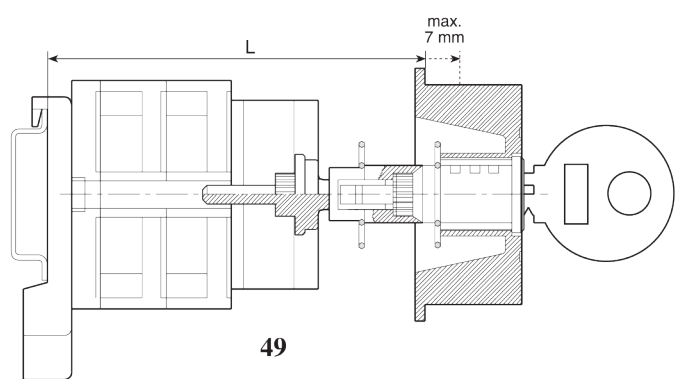
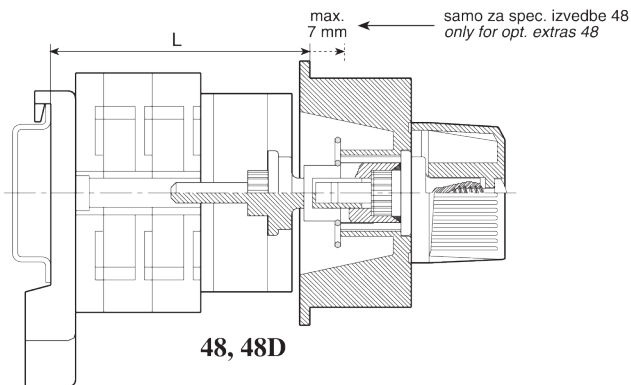

TIP / TYPE	BROJ ELEMENATA / NO. OF ELEMENTS								
	48			48D			49		
L(mm)	1	2	3	1	2	3	1	2	3
4G10	40-47	50-57	59-66	32,5	42	51,5	58-65	68-75	77-84

57, 58, 58D - Spojka za vrata / *Door coupling*

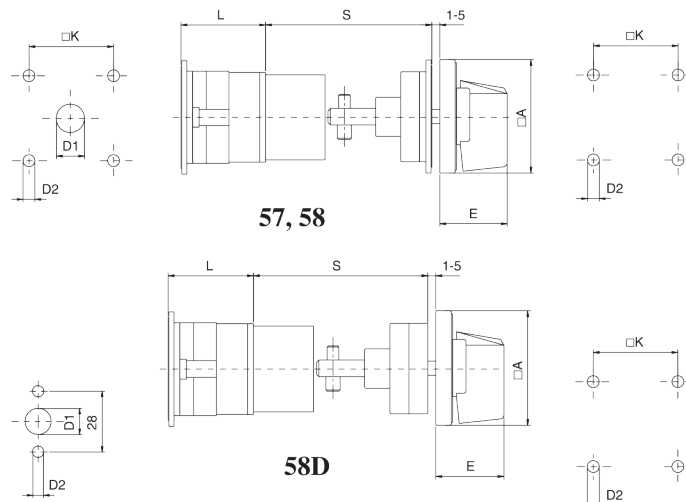

VELIČINA SIZE	A	D ₁	D ₂	E	K	S	BROJ ELEMENATA / NO. OF ELEMENTS - L(mm)											
							1	2	3	4	5	6	7	8	9	10	11	12
A0	48	12	5	26,5	36	45-55	40,5	50	59,5	69,5	79	88,5	98	107,5	117,5	127	136,5	146
A1	65	14	5	34,5	48	45-55	46	59,5	73	86,5	100,5	114	127,5	141	154,5	168,5	182	195,5

NARUDŽBENI KOD / ORDERING CODE

Prilikom naručivanja sklopke potrebno je definirati:

- za **standardnu** izvedbu sklopke tri tipa podataka **1 2 3**
- za sklopku s **posebnom izvedbom** max. 5 tipova podataka **1 2 3 4 5**

When ordering please define:

- for **standard** switch three data types **1 2 3**
- for switch with an **optional extra** max. 5 data types **1 2 3 4 5**

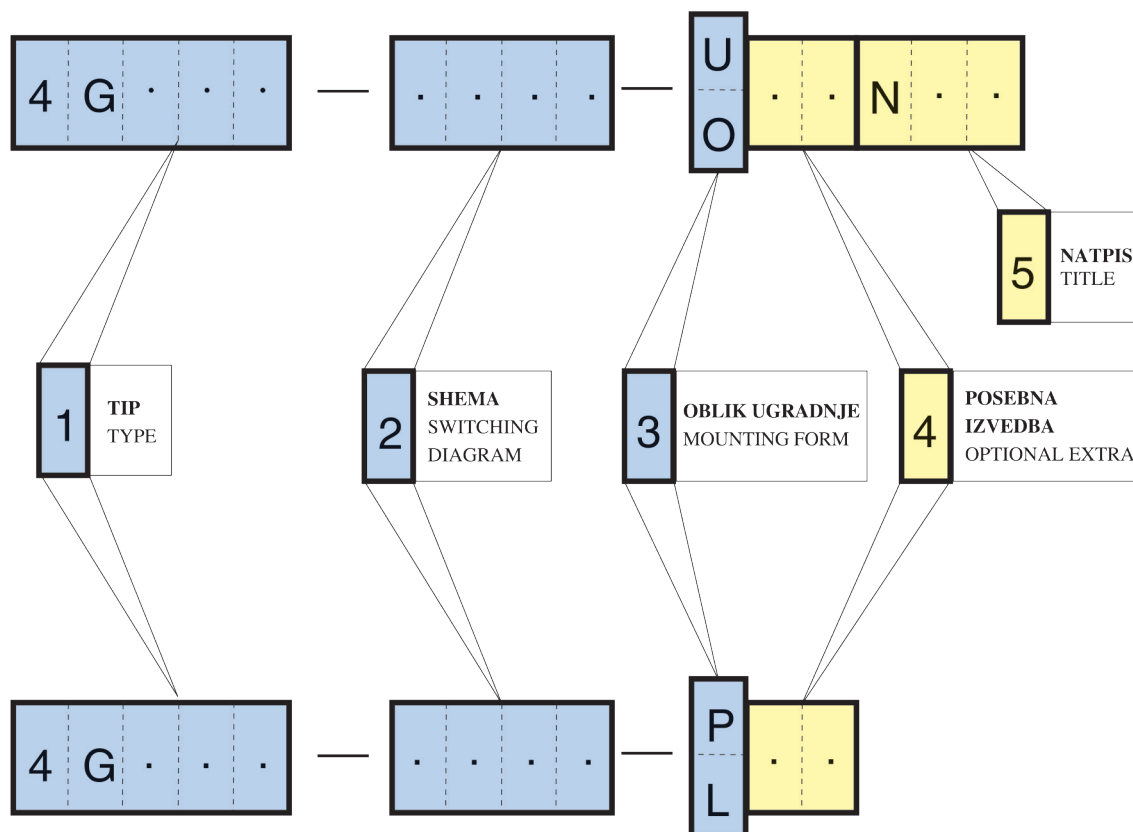

	OPIS	DESCRIPTION
1	Tip sklopke. Odabire se prema teh. zahtjevima (vidi str. 11) i ugradnoj veličini (vidi str. 3)	Switch type. To be chosen in accordance with the technical requests (see page 11) and mounting size (see page 3)
2	Schema. Odabire se prema programu sklapanja (vidi stranu 12 i 13)	Switching diagram. To be chosen in accordance with the switching programme. (see pages 12 - 13)
3	Standardni oblici ugradnje U,O (vidi str. 3) U - Ugradna O - Odvojena P - Plastično kućište L - Limeno kućište	Standard mounting forms U,O (see page 3) U - Front O - Rear P - Plastic casing L - Steel casing
4	Posebna izvedba (vidi str. 6 - 10)	To be marked when an optional extra is required (see pages 6 - 10)
5	"N" se upisuje ako se traži prednja ploča s natpisom. Potrebno je upisati željeni tekst.	"N" is to be written when the front plate with a title is required. Please define required text.

NARUDŽBENI LIST ZA SPECIJALNE SKLOPKE / ORDER SHEET FOR SPECIAL SWITCHES

Naručilatelj/Purchaser	Telefon/Phone	Telefax	Datum/Date
------------------------	---------------	---------	------------

Tip sklopke/Switch type:

4G ili/or
Podaci sklopke/Switch data:
Napon/Voltage _____ V
Struja/Current _____ A
Snaga/Power _____ kW
Opis primjene sklopke/Description of the equipment to be switched:

Oblik ugradnje/Mounting form:

- U - Ugradna/Front
- O - Odvojena/Rear
- P - Plastično kućište/Plastic casing
- L - Limeno kućište/Steel casing

Prednji sklop/Front part:



Ručica/ Handle	<input checked="" type="checkbox"/>	Prednja ploča/ Front plate	<input checked="" type="checkbox"/>	Podloga/ Escutch. plate	<input type="checkbox"/>
Crna/Black	<input checked="" type="checkbox"/>	Siva/Grey	<input type="checkbox"/>		<input type="checkbox"/>
Crvena/Red	<input type="checkbox"/>	Žuta/Yellow	<input type="checkbox"/>		
Bijela/White	<input type="checkbox"/>				<input checked="" type="checkbox"/>

Posebna izvedba/Optional extra:



Dodatni zahtjevi/Additional requirements:

Oblik/Form:

Ručica/
Handle

-  A0, A1, A2, A3
-  A1, A2, A3
-  A3

Prednja ploča/
Front plate









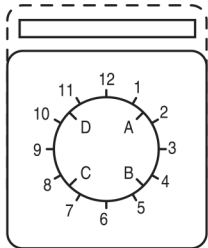















-  Standardna/Standard A0, A1, A2, A3
-  Sa natpisom/With title A0, A1

NAPOMENA: - Standardna kombinacija boja i oblika. Obavezno označiti željeni zahtjev (ili).

REMARK: - Standard combination of colours and forms. Please mark the desired request (or).

	Narudžbeni broj Order No.
---	------------------------------



1	4	5	8	9	12	13	16	17	20	21	24	25	28	29	32	33	36	37	40	41	44	45	48
																							
2	3	6	7	10	11	14	15	18	19	22	23	26	27	30	31	34	35	38	39	42	43	46	47

UPISATI ŽELJENU OZNAKU POLOŽAJA
PLEASE WRITE THE DESIRED SWITCH POS. MARKS

UPISATI ŽELJENU OZNAKU POLOŽAJA PLEASE WRITE THE DESIRED SWITCH POS. MARKS	7																											
	C																											
	8																											
	9																											
	D																											
	10																											
	11																											
	12																											
1																												
A																												
2																												
3																												
4																												
B																												
5																												
6																												

1	<input checked="" type="checkbox"/>			<input checked="" type="checkbox"/>									<input checked="" type="checkbox"/>		<input checked="" type="checkbox"/>													
2		<input checked="" type="checkbox"/>		<input checked="" type="checkbox"/>																								<input checked="" type="checkbox"/>

Preklapanje kontakata
Overlapping of contacts

Kontakt zatvoren preko 2 ili više položaja
Contact closed across 2 or more positions

Prolazni kontakt
Passing contact

Kontakt zatvoren
Contact closed

Samostalni povratni hod (30°)
Self return (30°)

Max. broj znakova
Max. number of characters

30° / 60°

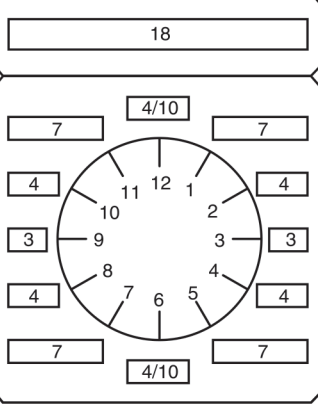

45° / 90°

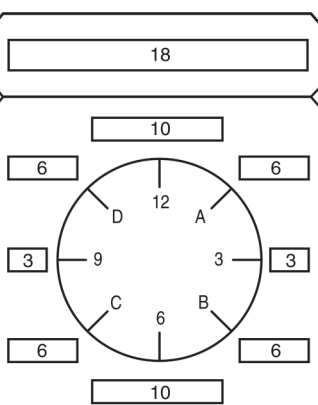

■ ROTARY CAM SWITCHES 4G SERIES



ENERGY AND AUTOMATION

www.LovatoElectric.hr

LOVATO ELECTRIC d.o.o.

Borongajska cesta 81 b
10002 ZAGREB

HRVATSKA

Tel +385 (0)1 2369 243, 2369 203

prodaja@LovatoElectric.hr

www.LovatoElectric.hr

Follow us



The products described in this document are subject to updates or modifications at any time. The descriptions, technical and functional information, illustrations and instructions in the leaflet are to be considered as purely illustrative, and consequently have no contractual relevance. Remember also that the products themselves must be used by qualified personnel, in compliance with current plant engineering and installation standards, in order to avoid injury to persons or damage to property.